

Basic Specification

Model	YS24U7G-100
Type	Low Side Scroll Compressor
Application	Medium Temp. Refrigeration
Power	3.5 HP
Capacity (BTU/Hr)	22922
Refrigerant	R454C
Displacement (in ³ /Rev)	3.54
Compressor Weight With Oil (lbs)	68.3
Oil Type	POE
Oil Kinematic Viscosity (cSt,104°F)	32
Oil Primary Charge (oz)	47.3
Oil Recharge (oz)	42.3
Rated Speed (r/min)	3500
IP Class Of Terminal Box	IP54
Compressor Colour	Black

Performance Specifications

Cooling Capacity (BTU/hr)	22922±7.5%
Input Power (W)	3084±7.5%
EER (BTU/Wh)	7.43±7.5%
Rated Operating Current (A)	10
Oil Circulation Rate(%)	≤1%
Rated Sound Power (dBA)	74
Max. Sound Power (dBA)	79
Max. Vibration Displacement (mil)	≤3.9

Test Condition	Rated Cooling	Oil Circulation	Sound & Vibration
Evaporating Temp. (°F)	20	20	20
Condensing Temp. (°F)	120	120	120
Return Gas Temp. (°F)	40	40	40
Liquid Temp. (°F)	120	120	120
Ambient Temp. (°F)	95	95	95

Electric Parameters

Motor Type	Three Phase Induction Motor
Motor Poles	2
Power Supply	208-230V/3~/60Hz
Locked Rotor Current (A)	136.0
Max. Operating Current (A)	14.4
Motor Insulation Class	B
Line to Line Resistance (Ω,77°F)	0.675±10%
Lowest Starting Voltage (V)	177
Dielectric Strength	2000VAC / 1s / 60Hz ≤5mA
Insulation Resistance (MΩ)	≥20
Ground Resistance(Ω)	≤0.1

Safety Operating Limitation

Tightness Test Pressure (psig)	551-580
High Side Max Running Pressure(psig)	328.8
Low Side Max Running Pressure(psig)	76.3
Discharge Temp. Limit (°F)	≤257 4.72in to Compressor Discharge Connection And Well Insulated

Operating Envelope

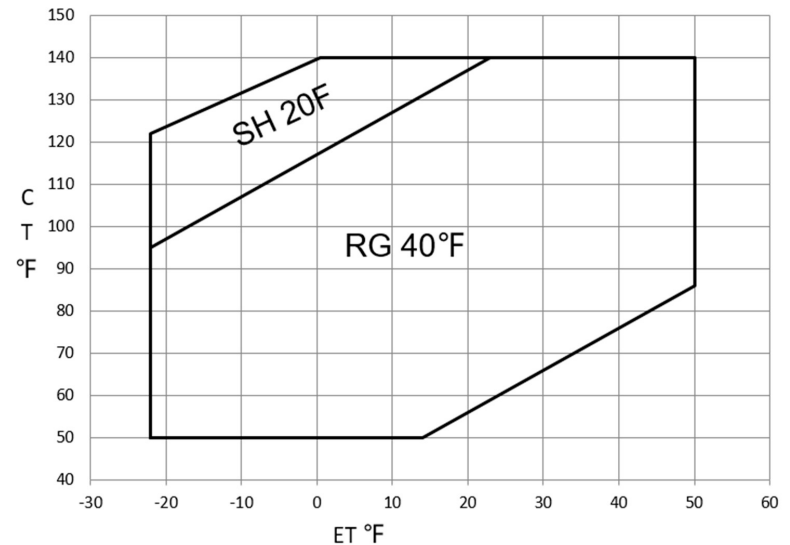

Performance Table

Item	c.T.(°C)	E.T.(°C)		-20	-10	0	10	20	30	40	50
		140	130								
Cooling Cap. (BTU/hr)	140					10345	14444	18881	23897	29728	36609
	130			9111	12936	16980	21469	26643	32737	39987	
	120	7422	11076	14806	18862	23468	28865	35288	42972		
	110	8920	12439	16140	20273	25062	30748	37565	45751		
	100	9921	13371	17109	21384	26422	32461	39739	48490		
	90	10606	14052	17893	22377	27728	34189	41993	51376		
	80	11148	14657	18665	23424	29155	36100	44495	54575		
	70	11727	15364	19606	24705	30882	38379	47432	58276		
	60	12517	16348	20889	26392	33080	41193	50968	62641		
	50	13697	17788	22694	28669	35934	44731	55295	67862		
Power (W)	140			3426	3585	3729	3861	3983	4097		
	130		2966	3119	3257	3384	3500	3610	3714		
	120	2574	2721	2853	2973	3085	3189	3289	3386		
	110	2380	2506	2620	2726	2825	2919	3011	3104		
	100	2207	2316	2415	2509	2598	2685	2773	2863		
	90	2050	2143	2230	2314	2396	2479	2564	2656		
	80	1901	1982	2059	2136	2213	2294	2381	2475		
	70	1753	1825	1895	1967	2042	2124	2214	2314		
	60	1600	1665	1730	1801	1877	1962	2058	2167		
	50	1435	1495	1559	1630	1709	1801	1905	2025		

» Performance Data Sheet Is Based On Limited Compressor Tests and Data Treatment, It Is Only a Reference for Compressor Selection.

» Return gas temperature within Envelope is 40°F, and Liquid Subcooling is 0F;

Compressor Protection Motor Protector

Internal Protector For Motor Protection	
Open Temp.(°F)	257±9
Close Temp.(°F)	158±18
Short Time Trip	103A 3-10s

High Pressure Relieve

Internal Pressure Protection	
Internal Pressure Relieve Valve Opening Pressure Difference (psi)	575.7-625.0

Accessory

Item	Drawing/Standard No.	Quantity
Grommet	070-0003-00	4
Sleeve	010-0014-00	4

Attentions

- » It is not allowed to perform vacuum in the system by using the refrigeration compressor. The compressor can start only after the refrigerant is charged;
- » It is not allowed to charge the refrigerant from the suction or discharge line closes to the compressor. The charge port should be arranged on the connection pipe of suction line accumulator or receiver, which is far away from the compressor, to avoid the liquid refrigerant flooding back;
- » The refrigerant charge amount complies with local regulations;
- » It is not allowed to run compressor in vacuum, not allowed to run compressor without refrigerant, and not allowed to run compressor in the reversed direction for long duration;
- » The compressor can only work with approved refrigerants;
- » The compressor is not allowed to work outside its envelope. System design should guarantee the suction line superheat and avoid the liquid refrigerant flooding back;
- » When the suction and discharge plugs are removed, the assembly and brazing should be done in 15 minutes;
- » The frequently start/stop compressor should be avoided. The suggested minimum continuous running time is 10 minutes to guarantee the safe oil level ($\geq 50\%$ initial charge volume), the suggested minimum interval between start and stop is 3 minutes.
- » A 70W crankcase heater is recommended to avoid the refrigerant migration during the off circle and flooded start. The crankcase heater should be powered on 12 hours earlier before the first start or restart after long duration off;
- » The system should be equipped with necessary protection devices for pressure, temperature, oil return, overcurrent and phase fault, etc.
- » The compressor is not allowed to lay down or place upside down during transportation, stock and installation. The maximum inclination is 15° when the compressor is running.

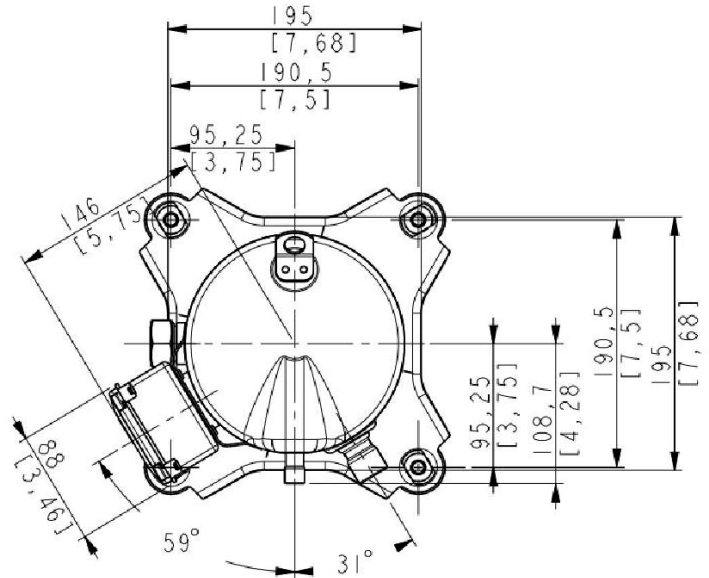

Wiring Diagram

WRING DIAGRAM

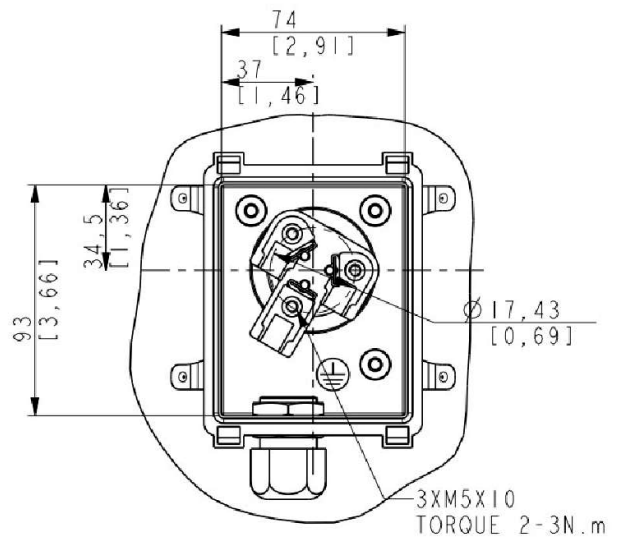

Compressor Drawings

Compressor Outline Drawing

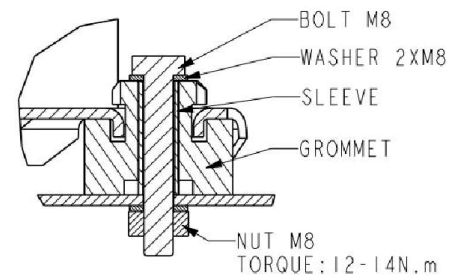
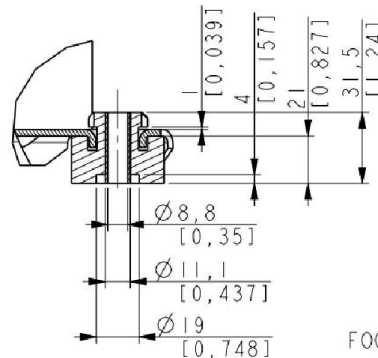
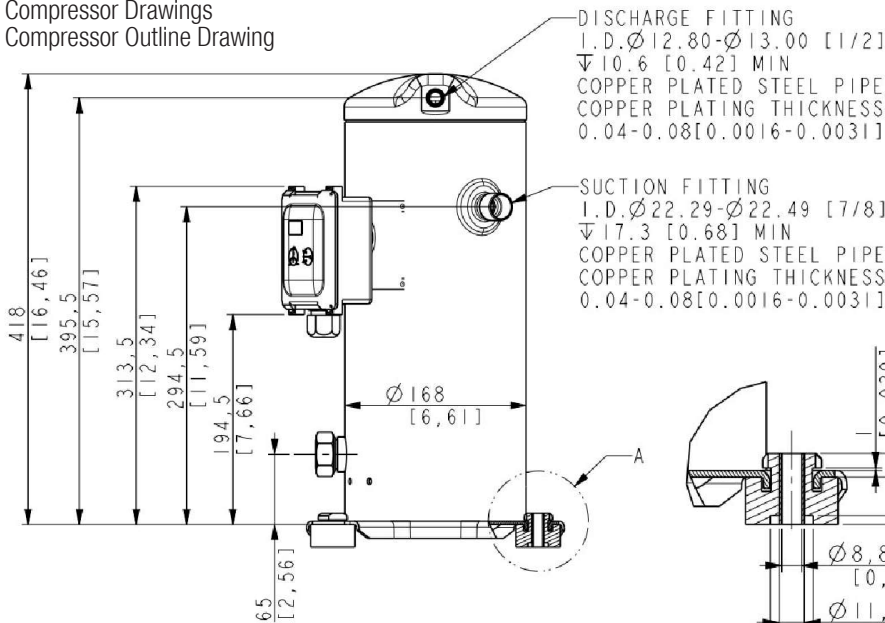

FOOT INSTALLATION RECOMMENDATION

NOTE
1. UNIT:mm[in]
1. ALL TOLERANCES UNLESS OTHERWISE SPECIFIED: $\pm 3 [0,12]$, $\pm 3^\circ [0,12^\circ]$

Mounting Sleeve Drawing

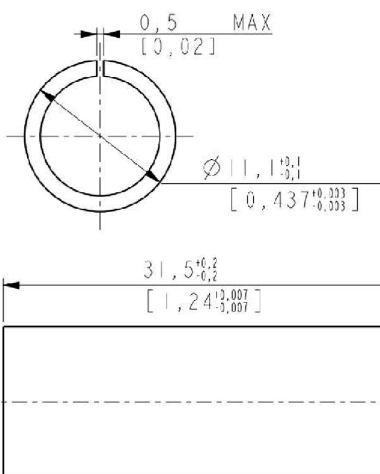

Grommet Drawing

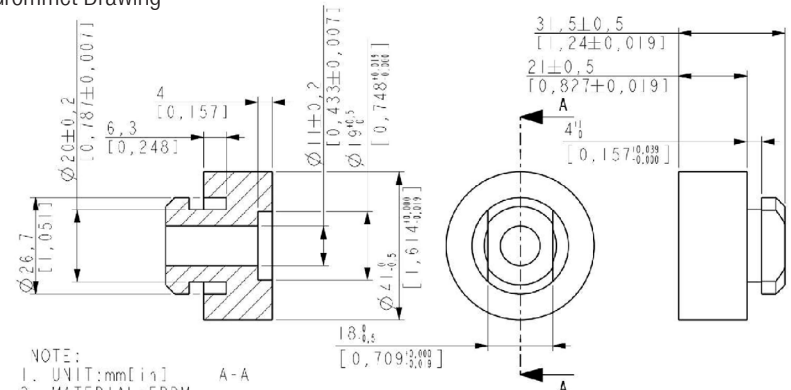

NOTE:
1. UNIT:mm[in] A-A
2. MATERIAL:EPDM, SHORE HARDNESS:55±5
3. UNMARKED TOLERANCE $\pm 0,15 [0,006]$

Application Guideline

- » See Details in the Application Guidelines for Invotech YS***U***_R454C.