

TECHNICAL DATASHEET: YH150A7

Archivo	Revisión	Elaboro	Hoja
YH150A7_TDS	03/2023	RGE	1

TEST CONDITION AHRI-540-2020 HIGH TEMPERATURE/AIR CONDITINING/CHILLERS						REFRIGERANT	ELECTRIC SUPPLY	TOLERANCE
Units	Te	Tc	SH	SC	Tret.	R-22	208-230V /3PH/50-60Hz	± 10%
Imperial °F	45	130	20	15	65			

NOMINAL TEST CONDITION PARAMETERS	Value	Imperial	Value	International	Comments
Frigorific potency	61849	Btuh	18,138	Watt	
Instant energy consumption	5295	Watt	5,295	Watt	
Efficiency BTUh/W (EER) W/W (COP)	11.68	Btuh/W	3.42	W/W	
Nominal current consumption	16.6	A	16.6	A	
Nominal Displacement	5.08	ln/Rev	83.3	Cm ² /Rev.	
Total heat rejection	79,905	Btuh	21,868	Watt	

Mechanical data	
Displacement at 3500 RPM	6.11 CFM
Commercial Horsepower	5HP
Compressor Weight	31 kg (68.2 Lb.)
3GS Oil original charge	1.4 L (49 Oz.)
3GS oil refilling charge	1.25 L (44 Oz.)
Center holes mounting	7.5 x 7.5 in
Required food print	9.5 x 9.5 in
Total height	418mm 16.5 in
Ø Discharge tube	½"
Ø Suction Tube	7/8"

Electrical data	
Max braker protection	15.5A
Locked Rotor Amp. LRA	99A
Voltage range	208 – 230 V AC
Phases	1
Electric supply frequency	50 - 60 HZ
VFD app range	30 - 70 Hz
Run capacitor	
Start capacitor	None
Start relay	None
Crankcase heater	70 W

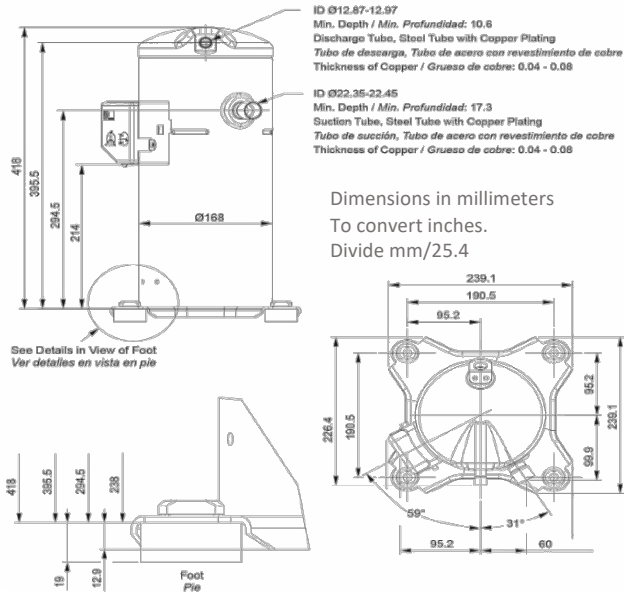

Dimensions in millimeters
To convert inches.
Divide mm/25.4

Frigorific potency in Btuh performance at different conditions in °F								
↓Tc Te→	-13	0	10	20	30	40	50	54
77	22199	31146	39377	48940	60005	72743	87258	93610
80	21789	30668	38831	48325	59322	71924	86336	92620
90	20423	29063	36986	46173	56863	69089	83125	89239
100	19057	27390	35040	43953	54233	66084	79676	85619
110		25716	33059	41597	51501	62908	76022	81759
120			30976	39138	48598	59561	72163	77695
130				36542	45558	56009	68065	73392

Instantaneous potency in W performance at different conditions in °F								
↓Tc Te→	-13	0	10	20	30	40	50	54
77	2531	2697	2781	2840	2886	2933	2993	3023
80	2634	2799	2882	2941	2987	3033	3093	3123
90	3000	3160	3239	3294	3338	3382	3439	3469
100	3412	3564	3638	3688	3727	3767	3820	3848
110		4027	4093	4136	4168	4201	4249	4275
120			4620	4653	4677	4702	4742	4765
130				5254	5267	5282	5312	5331

Current consumption in Ampere								
-13	0	10	20	30	40	50	54	
10.31	10.66	10.84	10.96	11.05	11.15	11.29	11.35	
10.5	10.86	11.04	11.16	11.26	11.36	11.49	11.56	
11.22	11.59	11.76	11.89	11.99	12.09	12.22	12.29	
12.09	12.45	12.62	12.74	12.83	12.93	13.06	13.13	
	13.49	13.66	13.76	13.84	13.93	14.04	14.11	
		14.91	15	15.06	15.13	15.22	15.28	
			16.49	16.53	16.57	16.64	16.69	

Mass flow in Lb/h								
-13	0	10	20	30	40	50	54	
125.09	175.86	220.32	270.52	327.68	392.65	466.71	499.03	
124.23	175.09	219.63	269.92	327.17	392.25	466.43	498.8	
121.47	172.48	217.18	267.65	325.13	390.46	464.93	497.43	
118.73	169.69	214.39	264.9	322.45	387.89	462.5	495.06	
	166.65	211.2	261.6	319.06	384.45	459.05	491.61	
		207.5	257.63	314.86	380.05	454.47	486.98	
			252.92	309.76	374.59	448.7	481.08	