

Basic Specification	
Model	YF13E7G-Q100
Type	Low Side Shell Design Scroll Compressor
Application	Refrigeration
Power	2 HP
Capacity (BTU/Hr)	5372
Refrigerant	R448A/R449A
Displacement(cc/rev)	33.3
Cooling Capacity(W) ^(a)	1574
Input Power(W) ^(a)	1464
RLA(A) ^(a)	4.3
Cooling COP(W/W) ^(a)	1.07
Power Supply	208-230V/3~/60Hz
Min. Operating Voltage(V)	187
Max. Operating Voltage(V)	253
LRA(A)	88
Max. Operating Current(A) ^(b)	8.3
Rated Speed(r/min) ^(a)	3500
Compressor Weight (With Oil)(kg)	30
Oil Type	POE
Oil Kinematic Viscosity(cSt, 40°C)	32
Oil Density(kg/L, 20°C)	0.977
Primary Charge(L)	1.4
Recharge(L)	1.25
Oil Circulation Rate ^(a)	≤1%
Rated Sound(Sound Power)(dBA) ^(c)	73
Max. Operating Sound in Running Envelope (Sound Power)(dBA)	78
Vibration Displacement Peak-Peak(mm) ^(d)	≤0.09
Moisture(mg)	≤500
Impurity(mg)	≤80
LVS(V) ^(e)	177
MOV (V) ^(f)	187
Start Capacitor(μF/V)	/
Start Relay	/
Run Capacitor(μF/V)	/
IP Class of Terminal Box	IP21
Compressor Color	Black

Motor Parameters	
Motor Type	Three-phase asynchronous motor
Motor Pole	2
Motor Insulation Class(°C)	130(B Class)
Line to Line Resistance UV(CS)(Ω, 25°C)	0.784(±10%)
Line to Line Resistance UW(CR)(Ω, 25°C)	0.784(±10%)
Line to Line Resistance VW(SR)(Ω, 25°C)	0.784(±10%)
Dielectric Strength	2000VAC / 1s / 60Hz, Leakage Current≤5mA
Insulation Resistance(MΩ)	≥20
Ground Resistance(Ω)	≤0.1

Safety Operating Limit	
Tightness Test Pressure (MPa)	3.8-4.0
Max. Operating Pressure	
High Side(MPa)	H3.2/L2.0
Low Side(MPa)	
Compressor FreeSpace(Without Oil)	
High Side(L)	H1.0/L3.8
Low Side(L)	
Max. Refrigerant Charge(kg)	See Notes
Discharge Temperature Limit(°C)	≤120 (120mm to compressor discharge connection and well insulated)
Start-Stop Interval	See Notes

Performance Condition:

Condition	Condition Description
a	Rated Condition
b	Max. Load Condition, 90% Rated Voltage
c	Rated Condition, A Weighted Sound Power
d	Rated Condition, Max Operating Normal Displacement of Compressor Housing
e	Discharge Pressure and Suction Pressure: Saturated Refrigerant Pressure at 40°C
f	Max. Load Condition

2. Rated Condition, 48 Hours Break-in-Running before implementing Performance and Sound Testing

Item	Rated Condition	Max. Load Condition
E.T.(°C)/C.T.(°C)/S.H.(K)/S.C.(K)/A.T.(°C)	-31.6/40.6/36/0/35	0/60/20/0/46.1
Cooling Capacity Deviation	≥90.0%	-
Power Deviation	≤110.0%	-
COP Deviation	≥90.0%	-

3. Internal Protector

Protection Method	Config	Parameter		
Internal Overload Protector	With	Vendor	Vendor 1	Vendor 2
		Model	37HM408-XX	
		Open Temp.(°C)	125±5	
		Close Temp. (°C)	60±9	
		Short Time Trip	64A 2-10s	A S
Internal Pressure Relieve Valve	Without	2.76-3.10MPa		

4. Accessory

Item	Name	P.N.	PCS
1	Grommet	070-0003-00	4
2	Sleeve	010-0014-00	4
3	TREV	100-0002-01	1

5. Compressor Operating Envelope

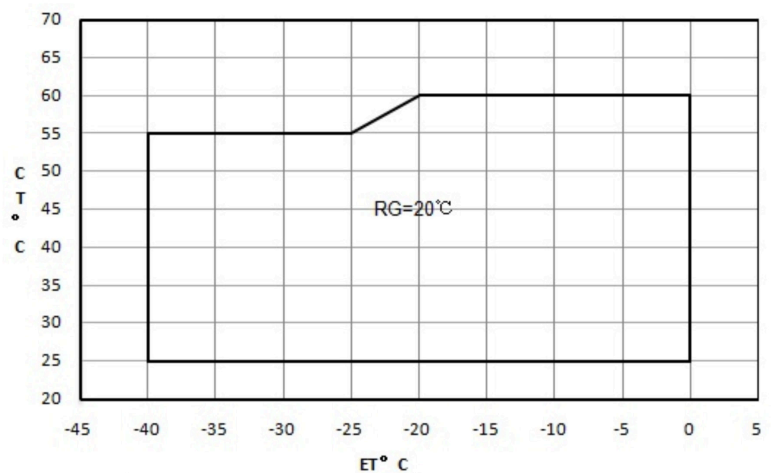

Compressor Performance Sheet

- » Performance Based on Superheat is within the Operating Envelope, Subcooling after Condenser is OK;
- » Performance Calculated by Coefficients of Polynomial is Only Suitable for the Condition within Operating Envelope
- » Capacity, Power can be Calculated by Coefficients of Polynomial

Performance Table										
Item	E.T.(°C) C.T.(°C)	-40	-35	-30	-25	-20	-15	-10	-5	0
		Cooling Cap. (W)	60					2229	2721	3303
55	933		1244	1586	1975	2429	2964	3598	4347	5228
50	1030		1350	1709	2124	2612	3189	3873	4681	5629
45	1116		1445	1820	2260	2781	3399	4133	4998	6012
40	1195		1531	1922	2386	2938	3597	4380	5302	6381
35	1269		1612	2018	2504	3089	3787	4617	5595	6739
30	1342		1691	2111	2619	3234	3971	4848	5881	7088
Power (W)	25	1418	1771	2204	2734	3378	4153	5075	6163	7433
	60					2688	2727	2757	2786	2821
	55	1988	2127	2231	2307	2362	2402	2436	2470	2510
	50	1721	1856	1957	2032	2087	2130	2166	2203	2249
	45	1500	1631	1730	1803	1858	1901	1939	1980	2029
	40	1320	1446	1541	1612	1665	1708	1748	1790	1844
	35	1172	1293	1384	1451	1502	1544	1584	1629	1685
30	1049	1164	1249	1312	1361	1402	1441	1486	1545	
25	943	1051	1130	1189	1234	1272	1311	1356	1416	

Ten Coefficients of Polynomial			
Expression	$z = p_0 + p_1*x + p_2*y + p_3*x^2 + p_4*x*y + p_5*y^2 + p_6*x^3 + p_7*x^2*y + p_8*x*y^2 + p_9*y^3$		
Description	z: Cooling Capacity(W) or Power (W) Specially: Heating Capacity(W)=Cooling Capacity(W)+Power (W) x: E.T. °C y: C.T. °C p0~p9: Coefficients of Polynomial		
Cooling Cap. Factor	Value	Power Factor	Value
p0	9186.626881	p0	672.9527513
p1	337.1565832	p1	13.51730179
p2	-74.3760474	p2	40.60381048
p3	4.800628043	p3	0.540377536
p4	-2.46897919	p4	0.084130378
p5	0.272842764	p5	-0.689798781
p6	0.022629708	p6	0.009261116
p7	-0.03297129	p7	-0.004827785
p8	-0.00354152	p8	-0.002949837
p9	-0.0041675	p9	0.010161502

Notes: Coefficients of polynomial are based on the fitting results of some sample data, which can be used as a reference of compressor selection, but cannot completely eliminate customer's test.

Drawings
Outline Drawing

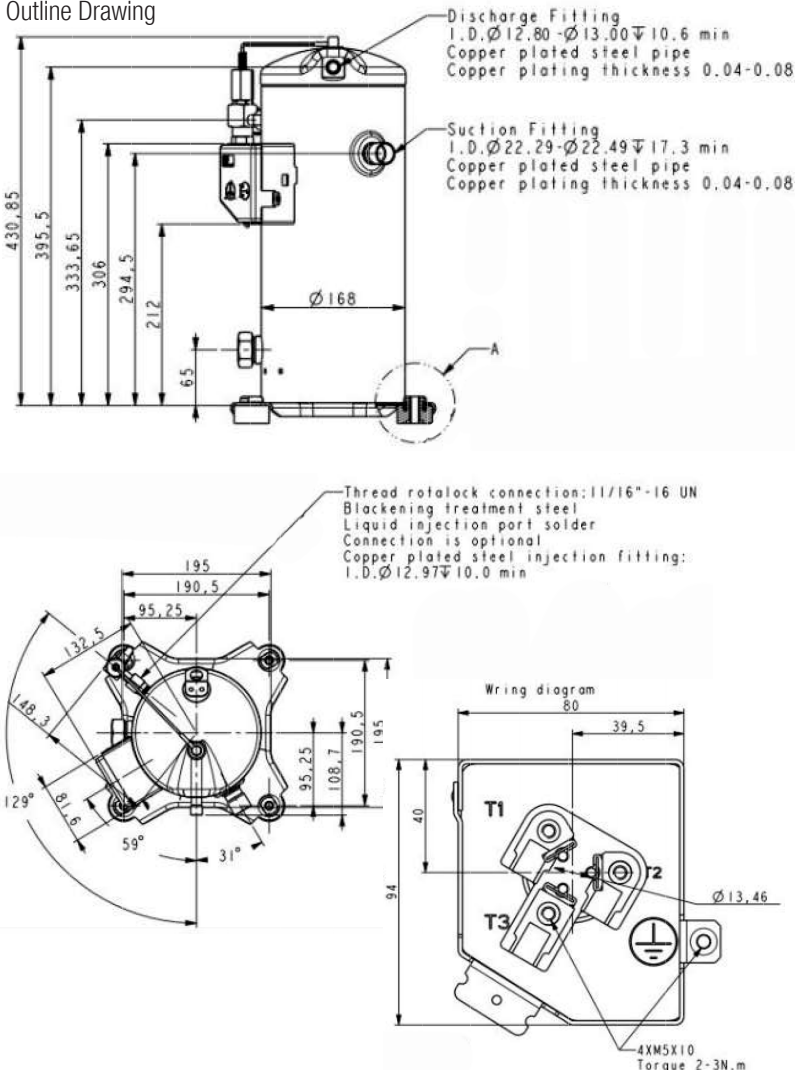

Notes

- It is not allowed to perform vacuum in the system by using the refrigeration compressor. The compressor can start only after the refrigerant charged. In some cases, such as on the field site, if it is limited by the situation that can't charge the required volume of refrigerant, 50% of the required refrigerant is charged necessary before the compressor starts. Double check the system and make sure everything is under safe status, then power on the compressor and charge the remained refrigerant when the compressor is running.
- It is not allowed to charge the refrigerant from the suction or discharge line closes to the compressor. The charge port should be arranged on the connection pipe of suction line accumulator or receiver, which is on the side far away to the compressor, to avoid the liquid refrigerant flood back.
- Refrigerant charge limitation: the ratio between the weight of oil and refrigerant should be ≥ 0.4 .
- It is not allowed to vacuum by compressor, not allowed to run the compressor without refrigerant, and not allowed to run the compressor on the reversed direction for long duration.
- The compressor can only work with approved refrigerant.
- The compressor is not allowed to work outside its envelope, the system should guarantee the suction line superheat and avoid the liquid refrigerant flood back.
- When the suction and discharge plugs are removed, the assembly and brazing should be done in 15 minutes.
- The frequently start/stop should be avoided. The suggested minimum continuous running time is 10 minutes to guarantee the safe oil level ($\geq 50\%$ initial charge volume), the suggested minimum interval duration between start and stop is 3 minutes.
- The deviation of supplied voltage should be less than $\pm 10\%$ of rated voltage.
- A 70W crankcase heater is recommended to avoid the refrigerant migration during the off circle and flood start. The crankcase heater should be power on 12 hours earlier than the first start or restart after long duration off.
- The system should be equipped with necessary protection devices, such as pressure, temperature, oil return, overcurrent and phase fault, etc.
- The compressor is not allowed to lay down or place upside down during transportation, stock and installation. The maximum inclination is 15° when the compressor is running.

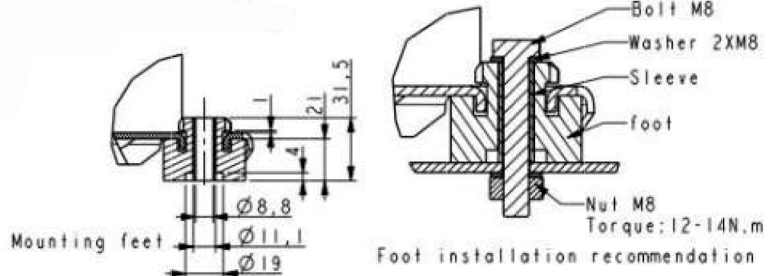

Sleeve Drawing

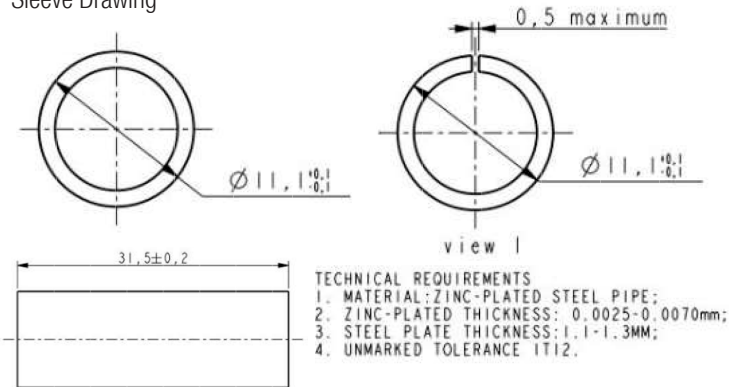

Grommet Drawing

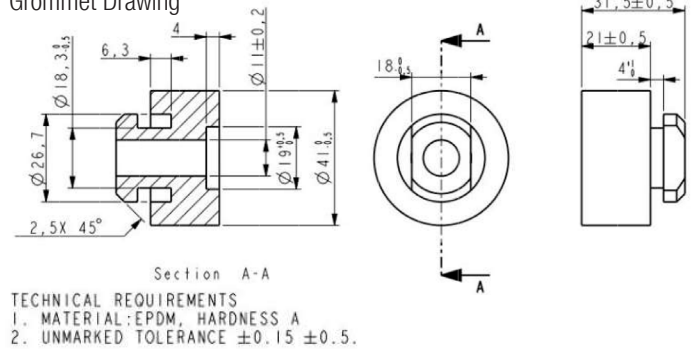

Single Phase Compressor Wiring Diagram
Only for single phase

Application

- See Details in the YF serial LBP refrigerant scroll compressor application manual