

Basic Specification

Model	YF17E7G-Q100 (Including Extended Models)
Type	Low Side Shell Design Scroll Compressor
Application	Refrigeration
Power	2.5 HP
Capacity (BTU/Hr)	6860
Refrigerant	R448A/R449A
Displacement(cc/rev)	42
Cooling Capacity(W) ^(a)	2010
Input Power(W) ^(a)	1855
RLA(A) ^(a)	5.5
Cooling COP(W/W) ^(a)	1.08
Power Supply	208-230V/3~/60Hz
Min. Operating Voltage(V)	187
Max. Operating Voltage(V)	253
LRA(A)	88
Max. Operating Current(A) ^(b)	10.6
Rated Speed(r/min) ^(a)	3500
Compressor Weight (With Oil)(kg)	30
Oil Type	POE
Oil Kinematic Viscosity(cSt, 40°C)	32
Oil Density(kg/L, 20°C)	0.977
Primary Charge(L)	1.4
Recharge(L)	1.25
Oil Circulation Rate ^(a)	≤1%
Rated Sound(Sound Power)(dBA) ^(c)	73
Max. Operating Sound in Running Envelope (Sound Power)(dBA)	78
Vibration Displacement Peak-Peak(mm) ^(d)	≤0.09
Moisture(mg)	≤500
Impurity(mg)	≤80
LVS(V) ^(e)	177
MOV (V) ^(f)	187
Start Capacitor(μF/V)	/
Start Relay	/
Run Capacitor(μF/V)	/
IP Class of Terminal Box	IP21
Compressor Color	Black

Motor Parameters

Motor Type	Three-phase asynchronous motor
Motor Pole	2
Motor Insulation Class(°C)	130(B Class)
Line to Line Resistance UV(CS)(Ω, 25°C)	0.784(±10%)
Line to Line Resistance UW(CR)(Ω, 25°C)	0.784(±10%)
Line to Line Resistance VW(SR)(Ω, 25°C)	0.784(±10%)
Dielectric Strength	2000VAC / 1s / 60Hz, Leakage Current≤5mA
Insulation Resistance(MΩ)	≥20
Ground Resistance(Ω)	≤0.1

Safety Operating Limit

Tightness Test Pressure (MPa)	3.8-4.0
Max. Operating Pressure	
High Side(MPa) Low Side(MPa)	H3.2/L2.0
Compressor FreeSpace(Without Oil)	
High Side(L) Low Side(L)	H1.0/L3.8
Max. Refrigerant Charge(kg)	See Notes
Discharge Temperature Limit(°C)	≤120 (120mm to compressor discharge connection and well insulated)
Start-Stop Interval	See Notes

Performance Condition:

Condition	Condition Description
a	Rated Condition
b	Max. Load Condition, 90% Rated Voltage
c	Rated Condition, A Weighted Sound Power
d	Rated Condition, Max Operating Normal Displacement of Compressor Housing
e	Discharge Pressure and Suction Pressure: Saturated Refrigerant Pressure at 40°C
f	Max. Load Condition

2. Rated Condition, 48 Hours Break-in-Running before implementing Performance and Sound Testing

Item	Rated Condition	Max. Load Condition
E.T.(°C)/C.T.(°C)/S.H.(K)/ S.C.(K)/A.T.(°C)	-31.6/40.6/36/0/35	0/60/20/0/46.1
Cooling Capacity Deviation	≥90.0%	-
Power Deviation	≤110.0%	-
COP Deviation	≥90.0%	-

3. Internal Protector

Protection Method	Config	Parameter		
Internal Overload Protector	With	Vendor	Vendor 1	Vendor 2
		Model	37HM408-XX	
		Open Temp.(°C)	125±5	
		Close Temp. (°C)	60±9	
		Short Time Trip	64A 2-10s	A S
Internal Pressure Relieve Valve	Without	2.76-3.10MPa		

4. Accessory

Item	Name	P.N.	PCS
1	Grommet	070-0003-00	4
2	Sleeve	010-0014-00	4
3	TREV	100-0002-01	1

5. Compressor Operating Envelope

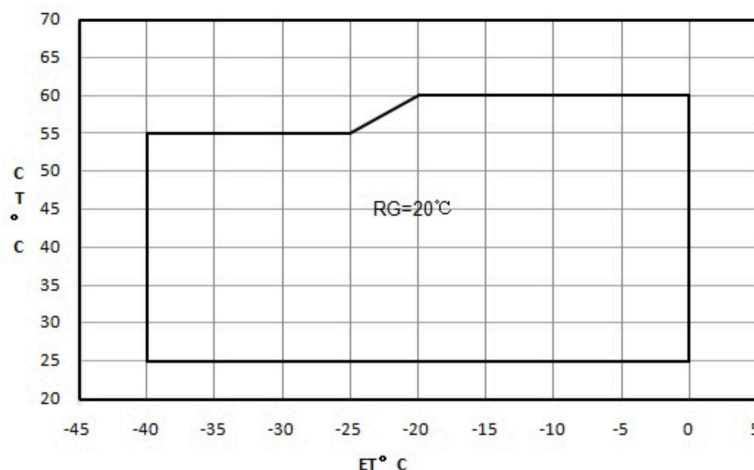

Compressor Performance Sheet

- » Performance Based on Superheat is within the Operating Envelope, Subcooling after Condenser is OK;
- » Performance Calculated by Coefficients of Polynomial is Only Suitable for the Condition within Operating Envelope
- » Capacity, Power can be Calculated by Coefficients of Polynomial

Performance Table										
Item	E.T.(°C) C.T.(°C)	-40	-35	-30	-25	-20	-15	-10	-5	0
Cooling Cap. (W)	60					2811	3432	4166	5036	6062
	55	1177	1569	2000	2491	3063	3738	4537	5482	6594
	50	1299	1703	2156	2679	3294	4022	4885	5904	7100
	45	1408	1822	2296	2850	3507	4287	5212	6304	7583
	40	1507	1931	2424	3009	3706	4537	5524	6687	8049
	35	1601	2033	2545	3159	3895	4776	5823	7057	8500
	30	1693	2132	2662	3304	4079	5009	6114	7418	8940
Power (W)	25	1788	2233	2780	3448	4260	5238	6401	7773	9374
	60					3390	3439	3477	3514	3558
	55	2508	2683	2814	2909	2979	3030	3073	3115	3166
	50	2170	2341	2469	2563	2633	2686	2732	2779	2836
	45	1892	2058	2182	2274	2343	2397	2446	2497	2559
	40	1665	1824	1944	2033	2100	2154	2204	2258	2325
	35	1479	1631	1745	1830	1895	1948	1998	2054	2125
30	1323	1468	1575	1655	1717	1768	1818	1875	1948	
25	1190	1325	1425	1499	1556	1605	1653	1710	1786	

Ten Coefficients of Polynomial			
Expression	$z = p_0 + p_1*x + p_2*y + p_3*x^2 + p_4*x*y + p_5*y^2 + p_6*x^3 + p_7*x^2*y + p_8*x*y^2 + p_9*y^3$		
Description	z: Cooling Capacity(W) or Power (W) Specially: Heating Capacity(W)=Cooling Capacity(W)+Power (W) x: E.T. °C y: C.T. °C p0~p9: Coefficients of Polynomial		
Cooling Cap. Factor	Value	Power Factor	Value
p0	11586.73661	p0	848.7692359
p1	425.2425373	p1	17.0488491
p2	-93.8076273	p2	51.21201322
p3	6.05484618	p3	0.681557253
p4	-3.11402781	p4	0.106110386
p5	0.344126009	p5	-0.870016481
p6	0.028541974	p6	0.011680687
p7	-0.04158541	p7	-0.006089099
p8	-0.00446678	p8	-0.003720515
p9	-0.00525631	p9	0.012816309

Notes: Coefficients of polynomial are based on the fitting results of some sample data, which can be used as a reference of compressor selection, but cannot completely eliminate customer's test.

Drawings
Outline Drawing

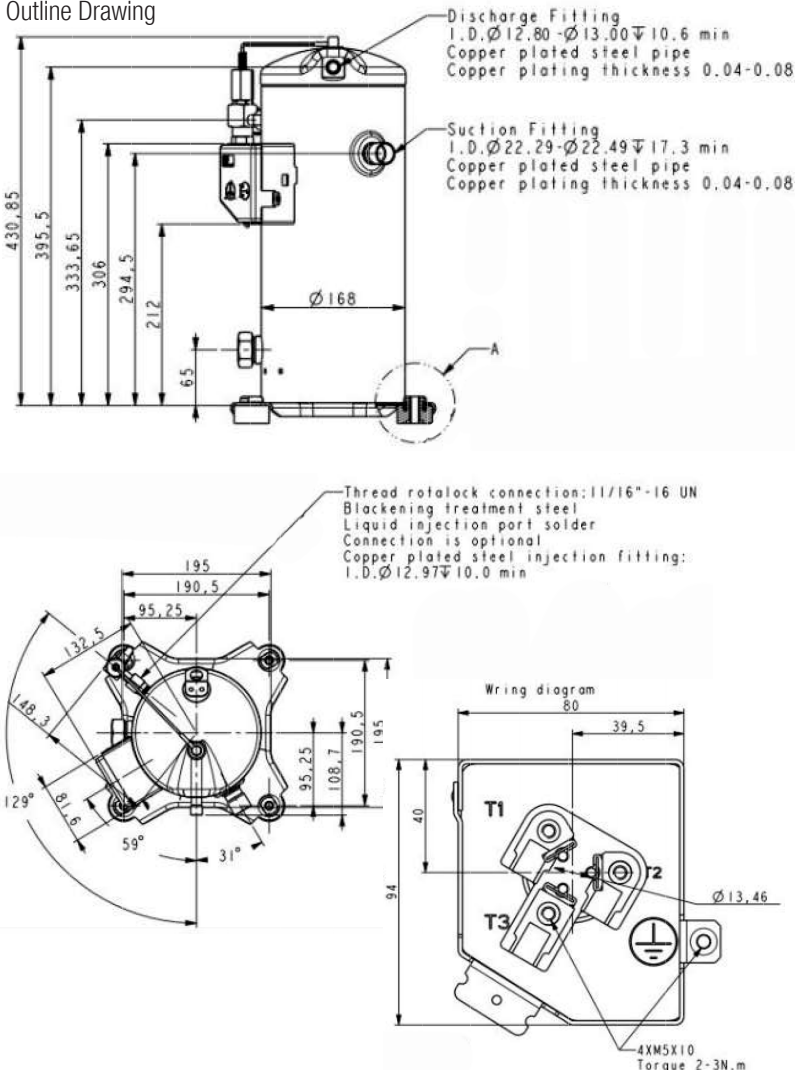

Notes

- It is not allowed to perform vacuum in the system by using the refrigeration compressor. The compressor can start only after the refrigerant charged. In some cases, such as on the field site, if it is limited by the situation that can't charge the required volume of refrigerant, 50% of the required refrigerant is charged necessary before the compressor starts. Double check the system and make sure everything is under safe status, then power on the compressor and charge the remained refrigerant when the compressor is running.
- It is not allowed to charge the refrigerant from the suction or discharge line closes to the compressor. The charge port should be arranged on the connection pipe of suction line accumulator or receiver, which is on the side far away to the compressor, to avoid the liquid refrigerant flood back.
- Refrigerant charge limitation: the ratio between the weight of oil and refrigerant should be ≥ 0.4 .
- It is not allowed to vacuum by compressor, not allowed to run the compressor without refrigerant, and not allowed to run the compressor on the reversed direction for long duration.
- The compressor can only work with approved refrigerant.
- The compressor is not allowed to work outside its envelope, the system should guarantee the suction line superheat and avoid the liquid refrigerant flood back.
- When the suction and discharge plugs are removed, the assembly and brazing should be done in 15 minutes.
- The frequently start/stop should be avoided. The suggested minimum continuous running time is 10 minutes to guarantee the safe oil level ($\geq 50\%$ initial charge volume), the suggested minimum interval duration between start and stop is 3 minutes.
- The deviation of supplied voltage should be less than $\pm 10\%$ of rated voltage.
- A 70W crankcase heater is recommended to avoid the refrigerant migration during the off circle and flood start. The crankcase heater should be power on 12 hours earlier than the first start or restart after long duration off.
- The system should be equipped with necessary protection devices, such as pressure, temperature, oil return, overcurrent and phase fault, etc.
- The compressor is not allowed to lay down or place upside down during transportation, stock and installation. The maximum inclination is 15° when the compressor is running.

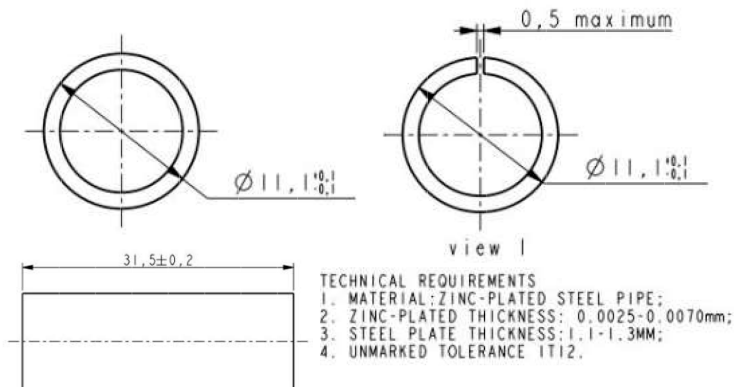
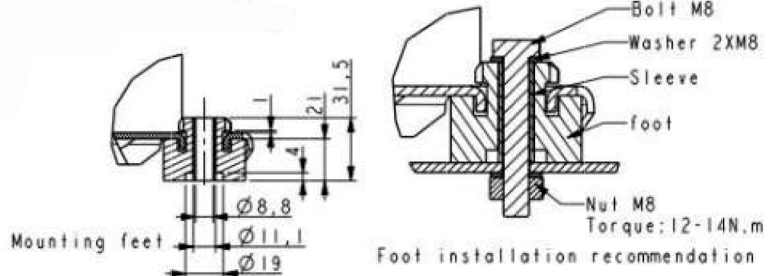

Grommet Drawing

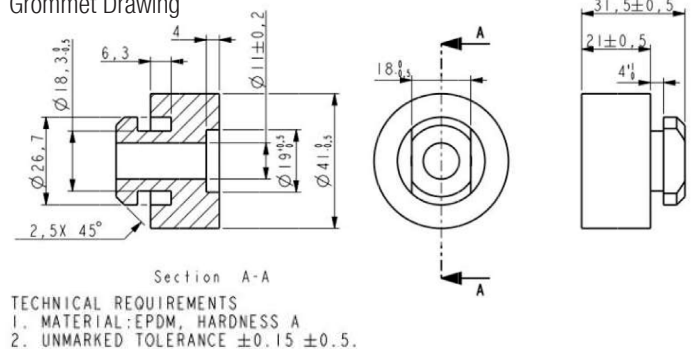

Single Phase Compressor Wiring Diagram
Only for single phase

Application

- See Details in the YF serial LBP refrigerant scroll compressor application manual