

Basic Specification	
Model	YF20E7S-Q100 (Including Extended Models)
Type	Low Side Shell Design Scroll Compressor
Application	Refrigeration
Power	3 HP
Capacity (BTU/Hr)	8055
Refrigerant	R448A/R449A
Displacement(cc/rev)	46.6
Cooling Capacity(W) <sup>(a)</sup>	2360
Input Power(W) <sup>(a)</sup>	2158
RLA(A) <sup>(a)</sup>	6.4
Cooling COP(W/W) <sup>(a)</sup>	1.09
Power Supply	208-230V/3~/60Hz
Min. Operating Voltage(V)	187
Max. Operating Voltage(V)	253
LRA(A)	88
Max. Operating Current(A) <sup>(b)</sup>	12.3
Rated Speed(r/min) <sup>(a)</sup>	3500
Compressor Weight (With Oil)(kg)	30
Oil Type	POE
Oil Kinematic Viscosity(cSt, 40°C)	32
Oil Density(kg/L, 20°C)	0.977
Primary Charge(L)	1.4
Recharge(L)	1.25
Oil Circulation Rate <sup>(a)</sup>	≤1%
Rated Sound(Sound Power)(dBA) <sup>(c)</sup>	73
Max. Operating Sound in Running Envelope (Sound Power)(dBA)	78
Vibration Displacement Peak-Peak(mm) <sup>(d)</sup>	≤0.09
Moisture(mg)	≤500
Impurity(mg)	≤80
LVS(V) <sup>(e)</sup>	177
MOV (V) <sup>(f)</sup>	187
Start Capacitor(μF/V)	/
Start Relay	/
Run Capacitor(μF/V)	/
IP Class of Terminal Box	IP21
Compressor Color	Black

Motor Parameters	
Motor Type	Three-phase asynchronous motor
Motor Pole	2
Motor Insulation Class(°C)	130(B Class)
Line to Line Resistance UV(CS)(Ω, 25°C)	0.784(±10%)
Line to Line Resistance UW(CR)(Ω, 25°C)	0.784(±10%)
Line to Line Resistance VW(SR)(Ω, 25°C)	0.784(±10%)
Dielectric Strength	2000VAC / 1s / 60Hz, Leakage Current≤5mA
Insulation Resistance(MΩ)	≥20
Ground Resistance(Ω)	≤0.1

Safety Operating Limit	
Tightness Test Pressure (MPa)	3.8-4.0
Max. Operating Pressure	
High Side(MPa) Low Side(MPa)	H3.2/L2.0
Compressor FreeSpace(Without Oil)	
High Side(L) Low Side(L)	H1.0/L3.8
Max. Refrigerant Charge(kg)	See Notes
Discharge Temperature Limit(°C)	≤120 (120mm to compressor discharge connection and well insulated)
Start-Stop Interval	See Notes

Performance Condition:

Condition	Condition Description
a	Rated Condition
b	Max. Load Condition, 90% Rated Voltage
c	Rated Condition, A Weighted Sound Power
d	Rated Condition, Max Operating Normal Displacement of Compressor Housing
e	Discharge Pressure and Suction Pressure: Saturated Refrigerant Pressure at 40°C
f	Max. Load Condition

2. Rated Condition, 48 Hours Break-in-Running before implementing Performance and Sound Testing

Item	Rated Condition	Max. Load Condition
E.T.(°C)/C.T.(°C)/S.H.(K)/ S.C.(K)/A.T.(°C)	-31.6/40.6/36/0/35	0/60/20/0/46.1
Cooling Capacity Deviation	≥90.0%	-
Power Deviation	≤110.0%	-
COP Deviation	≥90.0%	-

3. Internal Protector

Protection Method	Config	Parameter		
Internal Overload Protector	With	Vendor	Vendor 1	Vendor 2
		Model	37HM408-XX	
		Open Temp.(°C)	125±5	
		Close Temp. (°C)	60±9	
		Short Time Trip	64A 2-10s	A S
Internal Pressure Relieve Valve	Without	2.76-3.10MPa		

4. Accessory

Item	Name	P.N.	PCS
1	Grommet	070-0003-00	4
2	Sleeve	010-0014-00	4
3	TREV	100-0002-01	1

5. Compressor Operating Envelope

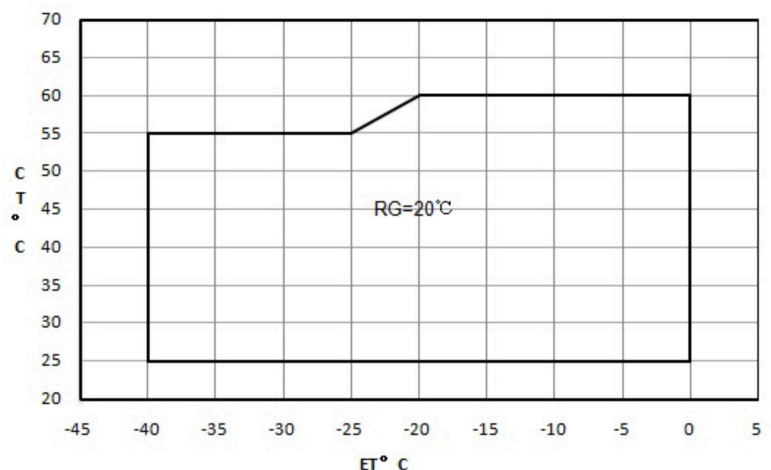

Compressor Performance Sheet

- » Performance Based on Superheat is within the Operating Envelope, Subcooling after Condenser is OK;
- » Performance Calculated by Coefficients of Polynomial is Only Suitable for the Condition within Operating Envelope
- » Capacity, Power can be Calculated by Coefficients of Polynomial

Performance Table

Item	ET(°C) C.T.(°C)	Temperature (°C)								
		-40	-35	-30	-25	-20	-15	-10	-5	0
Cooling Cap. (W)	60					3119	3807	4622	5587	6726
	55	1306	1741	2219	2764	3399	4148	5034	6083	7316
	50	1441	1889	2392	2972	3655	4463	5420	6550	7877
	45	1562	2022	2547	3163	3891	4757	5783	6994	8414
	40	1672	2142	2690	3338	4112	5034	6129	7420	8930
	35	1776	2255	2824	3505	4322	5300	6461	7830	9431
	30	1879	2366	2954	3666	4526	5557	6784	8230	9919
Power (W)	25	1984	2478	3084	3826	4727	5811	7103	8625	10401
	60					3762	3816	3858	3899	3947
	55	2782	2977	3122	3228	3305	3362	3409	3456	3513
	50	2408	2597	2739	2844	2921	2980	3031	3083	3147
	45	2100	2283	2421	2523	2600	2660	2713	2770	2840
	40	1847	2024	2157	2256	2330	2390	2446	2506	2580
	35	1641	1809	1936	2030	2102	2161	2217	2279	2358
30	1468	1628	1748	1837	1905	1961	2017	2080	2162	
25	1320	1470	1581	1664	1727	1780	1834	1898	1981	

Ten Coefficients of Polynomial

Expression	$z = p_0 + p_1x + p_2y + p_3x^2 + p_4xy + p_5y^2 + p_6x^3 + p_7x^2y + p_8xy^2 + p_9y^3$		
Description	z: Cooling Capacity(W) or Power (W) Specially: Heating Capacity(W)=Cooling Capacity(W)+Power (W) x: E.T. °C y: C.T. °C p0~p9: Coefficients of Polynomial		
Cooling Cap. Factor	Value	Power Factor	Value
p0	12855.76014	p0	941.729676
p1	471.81672	p1	18.916104
p2	-104.081796	p2	56.820948
p3	6.717996	p3	0.756204
p4	-3.455088	p4	0.117732
p5	0.381816	p5	-0.965304
p6	0.031668	p6	0.01296
p7	-0.04614	p7	-0.006756
p8	-0.004956	p8	-0.004128
p9	-0.005832	p9	0.01422

Notes: Coefficients of polynomial are based on the fitting results of some sample data, which can be used as a reference of compressor selection, but cannot completely eliminate customer's test.

Drawings  
Outline Drawing

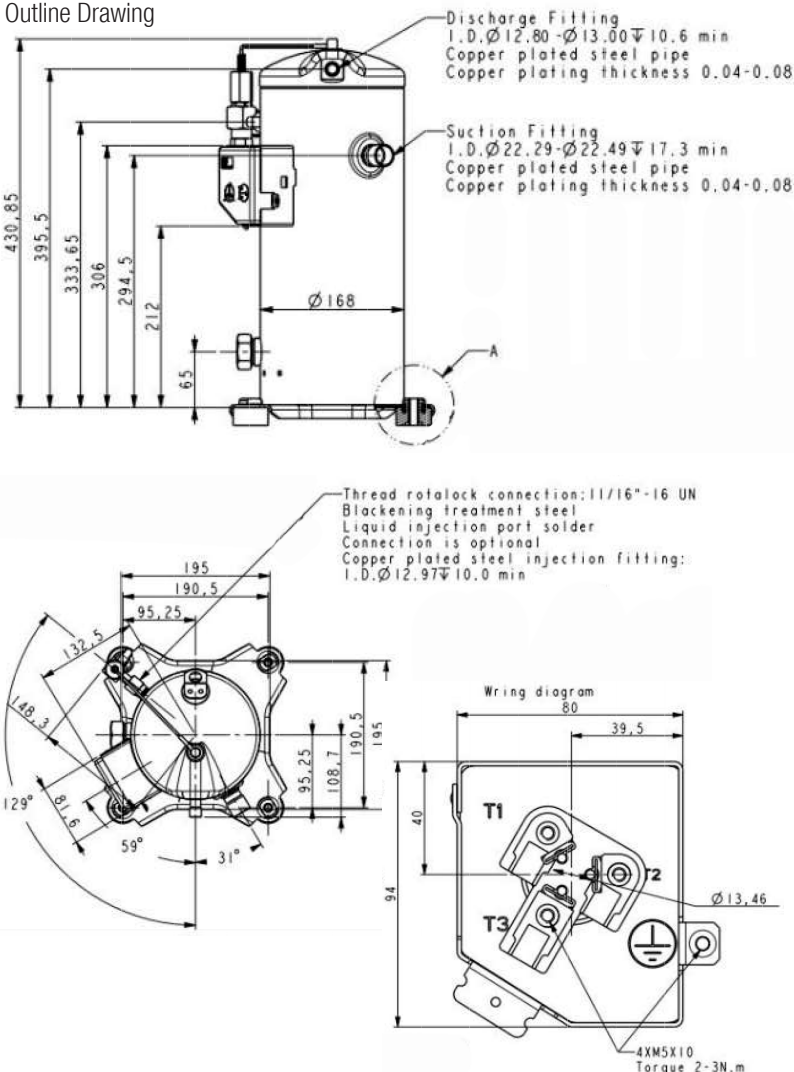

Notes

- It is not allowed to perform vacuum in the system by using the refrigeration compressor. The compressor can start only after the refrigerant charged. In some cases, such as on the field site, if it is limited by the situation that can't charge the required volume of refrigerant, 50% of the required refrigerant is charged necessary before the compressor starts. Double check the system and make sure everything is under safe status, then power on the compressor and charge the remained refrigerant when the compressor is running.
- It is not allowed to charge the refrigerant from the suction or discharge line closes to the compressor. The charge port should be arranged on the connection pipe of suction line accumulator or receiver, which is on the side far away to the compressor, to avoid the liquid refrigerant flood back.
- Refrigerant charge limitation: the ratio between the weight of oil and refrigerant should be  $\geq 0.4$ .
- It is not allowed to vacuum by compressor, not allowed to run the compressor without refrigerant, and not allowed to run the compressor on the reversed direction for long duration.
- The compressor can only work with approved refrigerant.
- The compressor is not allowed to work outside its envelope, the system should guarantee the suction line superheat and avoid the liquid refrigerant flood back.
- When the suction and discharge plugs are removed, the assembly and brazing should be done in 15 minutes.
- The frequently start/stop should be avoided. The suggested minimum continuous running time is 10 minutes to guarantee the safe oil level ( $\geq 50\%$  initial charge volume), the suggested minimum interval duration between start and stop is 3 minutes.
- The deviation of supplied voltage should be less than  $\pm 10\%$  of rated voltage.
- A 70W crankcase heater is recommended to avoid the refrigerant migration during the off circle and flood start. The crankcase heater should be power on 12 hours earlier than the first start or restart after long duration off.
- The system should be equipped with necessary protection devices, such as pressure, temperature, oil return, overcurrent and phase fault, etc.
- The compressor is not allowed to lay down or place upside down during transportation, stock and installation. The maximum inclination is  $15^\circ$  when the compressor is running.

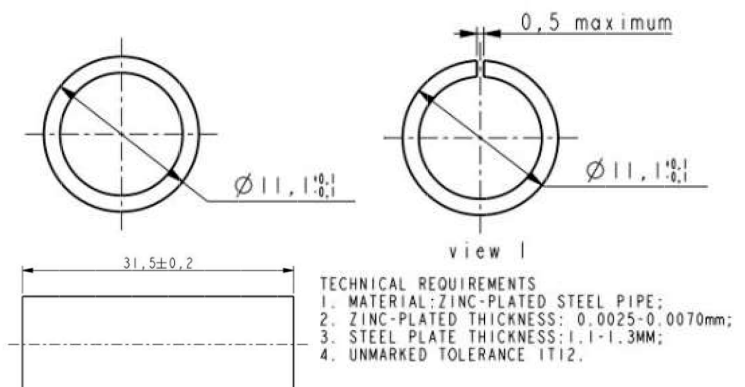
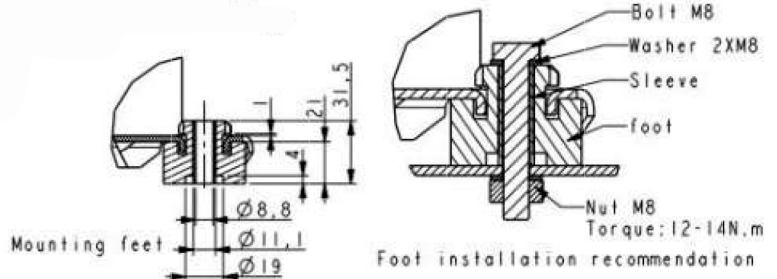

Grommet Drawing

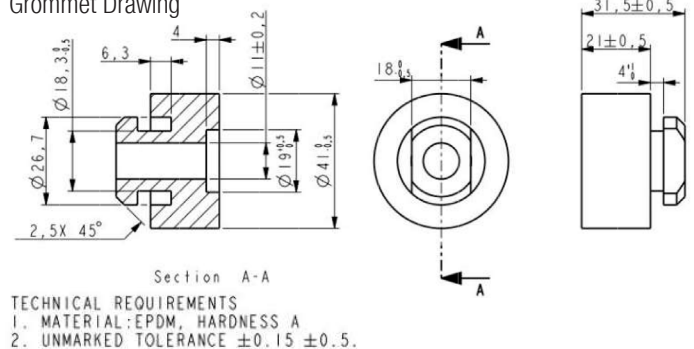

Single Phase Compressor Wiring Diagram  
Only for single phase

Application

- See Details in the YF serial LBP refrigerant scroll compressor application manual