

Basic Specification	
Model	YF29E7G-Q100 (Including Extended Model)
Type	Low Side Shell Design Scroll Compressor
Application	Refrigeration
Power	4 HP
Capacity (BTU/Hr)	11939
Refrigerant	R448A/R449A
Displacement(cc/rev)	67.8
Cooling Capacity(W) ^(a)	3498
Input Power(W) ^(a)	2900
RLA(A) ^(a)	8.5
Cooling COP(W/W) ^(a)	1.21
Power Supply	208-230V/3~/60Hz
Min. Operating Voltage(V)	187
Max. Operating Voltage(V)	253
LRA(A)	136
Max. Operating Current(A) ^(b)	18.2
Rated Speed(r/min) ^(a)	3500
Compressor Weight (With Oil)(kg)	31
Oil Type	POE
Oil Kinematic Viscosity(cSt, 40°C)	32
Oil Density(kg/L, 20°C)	0.977
Primary Charge(L)	1.6
Recharge(L)	1.45
Oil Circulation Rate ^(a)	≤1%
Rated Sound(Sound Power)(dBA) ^(c)	75
Max. Operating Sound in Running Envelope (Sound Power)(dBA)	80
Vibration Displacement Peak-Peak(mm) ^(d)	≤0.1
Moisture(mg)	≤500
Impurity(mg)	≤100
LVS(V) ^(e)	177
MOV (V) ^(f)	187
Start Capacitor(μF/V)	/
Start Relay	/
Run Capacitor(μF/V)	/
IP Class of Terminal Box	IP21
Compressor Color	Black

Motor Parameters	
Motor Type	Three-phase asynchronous motor
Motor Pole	2
Motor Insulation Class(°C)	130(B Class)
Line to Line Resistance UV(CS)(Ω, 25°C)	0.572(±10%)
Line to Line Resistance UW(CR)(Ω, 25°C)	0.572(±10%)
Line to Line Resistance VW(SR)(Ω, 25°C)	0.572(±10%)
Dielectric Strength	2000VAC / 1s / 60Hz, Leakage Current≤5mA
Insulation Resistance(MΩ)	≥20
Ground Resistance(Ω)	≤0.1

Safety Operating Limit	
Tightness Test Pressure (MPa)	3.8-4.0
Max. Operating Pressure	
High Side(MPa) Low Side(MPa)	H3.2/L2.0
Compressor FreeSpace(Without Oil)	
High Side(L) Low Side(L)	H1.0/L3.6
Max. Refrigerant Charge(kg)	See Notes
Discharge Temperature Limit(°C)	≤120 (120mm to compressor discharge connection and well insulated)
Start-Stop Interval	See Notes

Performance Condition:

Condition	Condition Description
a	Rated Condition
b	Max. Load Condition, 90% Rated Voltage
c	Rated Condition, A Weighted Sound Power
d	Rated Condition, Max Operating Normal Displacement of Compressor Housing
e	Discharge Pressure and Suction Pressure: Saturated Refrigerant Pressure at 40°C
f	Max. Load Condition

2. Rated Condition, 48 Hours Break-in-Running before implementing Performance and Sound Testing

Item	Rated Condition	Max. Load Condition
E.T.(°C)/C.T.(°C)/S.H.(K)/ S.C.(K)/A.T.(°C)	-31.6/40.6/36/0/35	0/60/20/0/46.1
Cooling Capacity Deviation	≥90.0%	-
Power Deviation	≤110.0%	-
COP Deviation	≥90.0%	-

3. Internal Protector

Protection Method	Config	Parameter		
Internal Overload Protector	With	Vendor	Vendor 1	Vendor 2
		Model	UP28LA05B-XX	
		Open Temp.(°C)	125±5	
		Close Temp. (°C)	70±10	
		Short Time Trip	103A 3-10s	A S
Internal Pressure Relieve Valve	Without	2.76-3.10MPa		

4. Accessory

Item	Name	P.N.	PCS
1	Grommet	070-0003-00	4
2	Sleeve	010-0014-00	4
3	TREV	100-0002-01	1

5. Compressor Operating Envelope

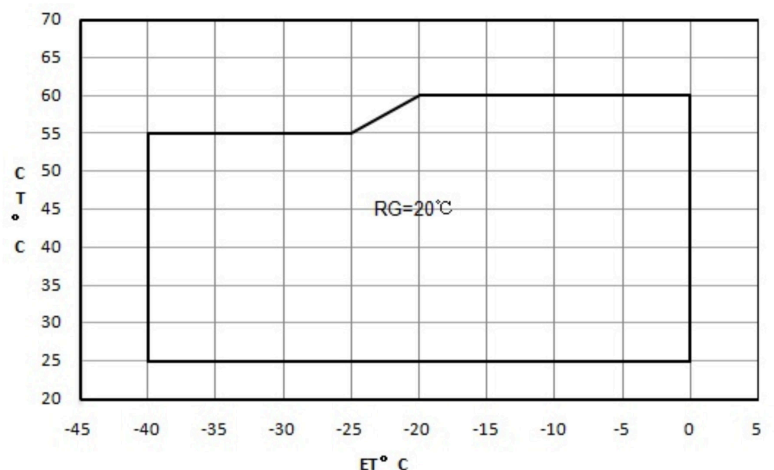

Compressor Performance Sheet

- » Performance Based on Superheat is within the Operating Envelope, Subcooling after Condenser is OK;
- » Performance Calculated by Coefficients of Polynomial is Only Suitable for the Condition within Operating Envelope
- » Capacity, Power can be Calculated by Coefficients of Polynomial

Performance Table										
Item	E.T. (°C) C.T. (°C)	-40	-35	-30	-25	-20	-15	-10	-5	0
		Cooling Cap. (W)	60					4402	5362	6520
55	1888		2494	3155	3909	4795	5851	7115	8626	10422
50	2038		2685	3398	4217	5178	6321	7684	9305	11223
45	2200		2880	3638	4512	5541	6763	8217	9940	11972
40	2366		3071	3866	4788	5876	7170	8706	10524	12662
35	2528		3250	4073	5035	6175	7532	9143	11047	13283
Power (W)	30	2677	3407	4251	5245	6429	7841	9519	11502	13828
	25	2804	3535	4391	5409	6629	8088	9825	11878	14286
	60					4840	4979	5134	5284	5407
	55	4119	4026	4026	4097	4219	4370	4528	4674	4785
	50	3516	3461	3490	3583	3719	3876	4032	4168	4262
	45	3035	3012	3065	3175	3318	3475	3625	3745	3815
40	2654	2657	2729	2849	2995	3147	3283	3382	3423	
35	2352	2376	2461	2585	2728	2869	2986	3059	3065	
30	2107	2145	2237	2361	2495	2619	2712	2752	2718	
25	1896	1944	2037	2154	2274	2376	2438	2440	2360	

Ten Coefficients of Polynomial			
Expression	$z = p_0 + p_1x + p_2y + p_3x^2 + p_4xy + p_5y^2 + p_6x^3 + p_7x^2y + p_8xy^2 + p_9y^3$		
Description	z: Cooling Capacity(W) or Power (W) Specially: Heating Capacity(W)=Cooling Capacity(W)+Power (W) x: E.T. °C y: C.T. °C p0~p9: Coefficients of Polynomial		
Cooling Cap. Factor	Value	Power Factor	Value
p0	14995.39387	p0	-353.4888356
p1	583.5696023	p1	-92.69993336
p2	33.00935381	p2	161.1788287
p3	9.02231611	p3	-2.848176259
p4	-1.75869456	p4	3.252221935
p5	-2.74063065	p5	-2.834267899
p6	0.051199174	p6	-0.02818787
p7	-0.04639376	p7	0.031635659
p8	-0.03192867	p8	-0.022728058
p9	0.011427515	p9	0.02913528

Notes: Coefficients of polynomial are based on the fitting results of some sample data, which can be used as a reference of compressor selection, but cannot completely eliminate customer's test.

Drawings
Outline Drawing

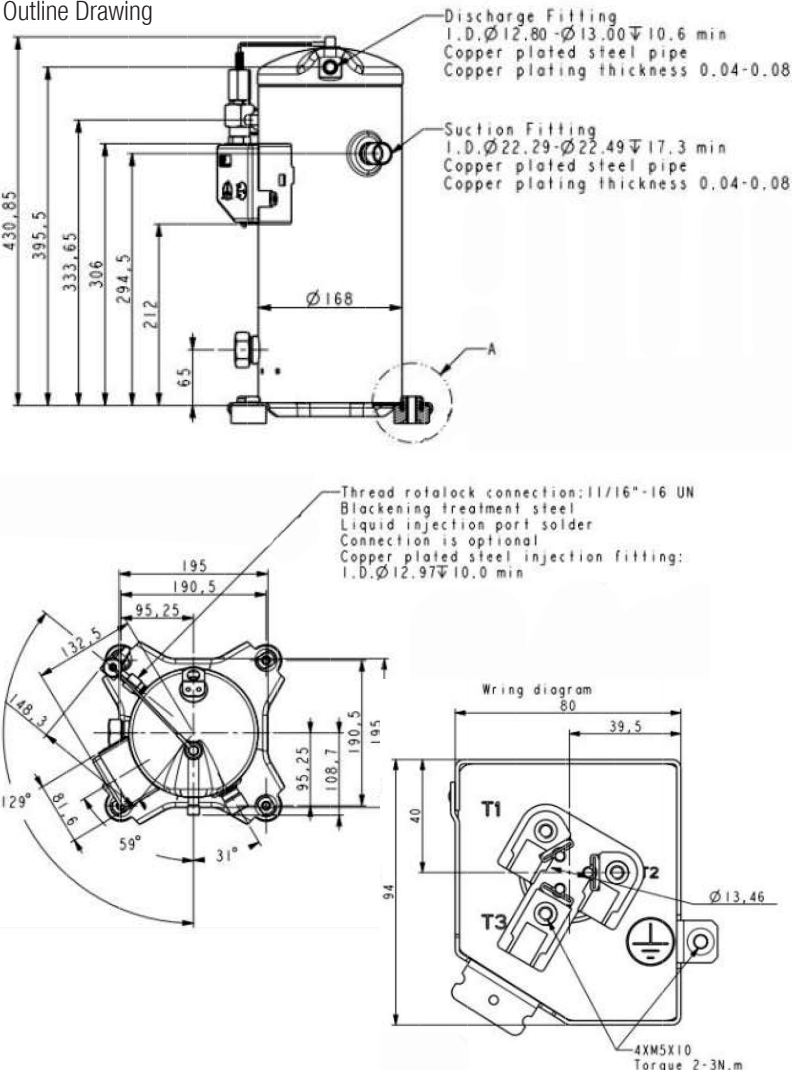

Notes

- It is not allowed to perform vacuum in the system by using the refrigeration compressor. The compressor can start only after the refrigerant charged. In some cases, such as on the field site, if it is limited by the situation that can't charge the required volume of refrigerant, 50% of the required refrigerant is charged necessary before the compressor starts. Double check the system and make sure everything is under safe status, then power on the compressor and charge the remained refrigerant when the compressor is running.
- It is not allowed to charge the refrigerant from the suction or discharge line closes to the compressor. The charge port should be arranged on the connection pipe of suction line accumulator or receiver, which is on the side far away to the compressor, to avoid the liquid refrigerant flood back.
- Refrigerant charge limitation: the ratio between the weight of oil and refrigerant should be ≥ 0.4 .
- It is not allowed to vacuum by compressor, not allowed to run the compressor without refrigerant, and not allowed to run the compressor on the reversed direction for long duration.
- The compressor can only work with approved refrigerant.
- The compressor is not allowed to work outside its envelope, the system should guarantee the suction line superheat and avoid the liquid refrigerant flood back.
- When the suction and discharge plugs are removed, the assembly and brazing should be done in 15 minutes.
- The frequently start/stop should be avoided. The suggested minimum continuous running time is 10 minutes to guarantee the safe oil level ($\geq 50\%$ initial charge volume), the suggested minimum interval duration between start and stop is 3 minutes.
- The deviation of supplied voltage should be less than $\pm 10\%$ of rated voltage.
- A 70W crankcase heater is recommended to avoid the refrigerant migration during the off circle and flood start. The crankcase heater should be power on 12 hours earlier than the first start or restart after long duration off.
- The system should be equipped with necessary protection devices, such as pressure, temperature, oil return, overcurrent and phase fault, etc.
- The compressor is not allowed to lay down or place upside down during transportation, stock and installation. The maximum inclination is 15° when the compressor is running.

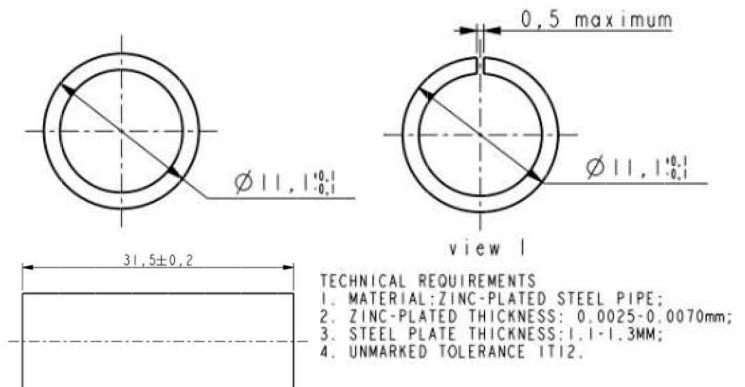
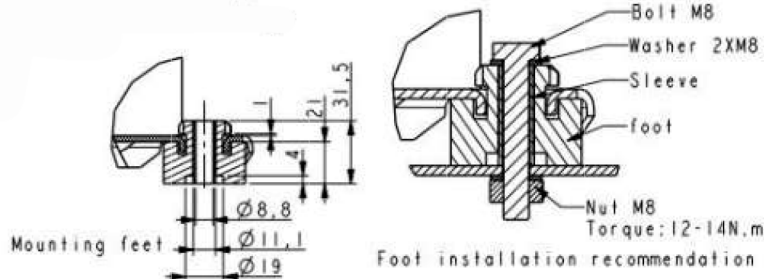

Grommet Drawing

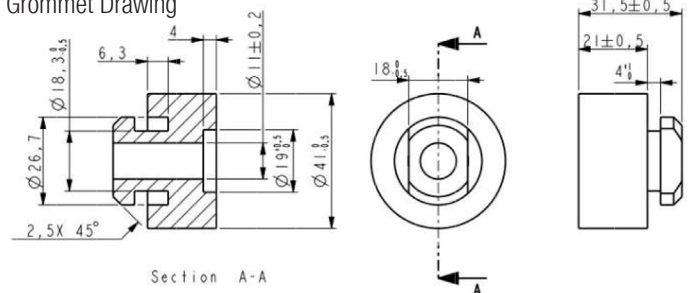

Single Phase Compressor Wiring Diagram
Only for single phase

Application

- See Details in the YF serial LBP refrigerant scroll compressor application manual