

Basic Specification	
Model	YF35E7G-Q100 (Including Extended Model)
Type	Low Side Shell Design Scroll Compressor
Application	Refrigeration
Power	5 HP
Capacity (BTU/Hr)	14164
Refrigerant	R448A/R449A
Displacement(cc/rev)	83.3
Cooling Capacity(W) ^(a)	4150
Input Power(W) ^(a)	3330
RLA(A) ^(a)	9.9
Cooling COP(W/W) ^(a)	1.25
Power Supply	208-230V/3~/60Hz
Min. Operating Voltage(V)	187
Max. Operating Voltage(V)	253
LRA(A)	136
Max. Operating Current(A) ^(b)	21.3
Rated Speed(r/min) ^(a)	3500
Compressor Weight (With Oil)(kg)	31
Oil Type	POE
Oil Kinematic Viscosity(cSt, 40°C)	32
Oil Density(kg/L, 20°C)	0.977
Primary Charge(L)	1.6
Recharge(L)	1.45
Oil Circulation Rate ^(a)	≤1%
Rated Sound(Sound Power)(dBA) ^(c)	75
Max. Operating Sound in Running Envelope (Sound Power)(dBA)	80
Vibration Displacement Peak-Peak(mm) ^(d)	≤0.1
Moisture(mg)	≤500
Impurity(mg)	≤100
LVS(V) ^(e)	177
MOV (V) ^(f)	187
Start Capacitor(μF/V)	/
Start Relay	/
Run Capacitor(μF/V)	/
IP Class of Terminal Box	IP21
Compressor Color	Black

Motor Parameters	
Motor Type	Three-phase asynchronous motor
Motor Pole	2
Motor Insulation Class(°C)	130(B Class)
Line to Line Resistance UV(CS)(Ω, 25°C)	0.572(±10%)
Line to Line Resistance UW(CR)(Ω, 25°C)	0.572(±10%)
Line to Line Resistance VW(SR)(Ω, 25°C)	0.572(±10%)
Dielectric Strength	2000VAC / 1s / 60Hz, Leakage Current≤5mA
Insulation Resistance(MΩ)	≥20
Ground Resistance(Ω)	≤0.1

Safety Operating Limit	
Tightness Test Pressure (MPa)	3.8-4.0
Max. Operating Pressure	
High Side(MPa) Low Side(MPa)	H3.2/L2.0
Compressor FreeSpace(Without Oil)	
High Side(L) Low Side(L)	H1.0/L3.6
Max. Refrigerant Charge(kg)	See Notes
Discharge Temperature Limit(°C)	≤120 (120mm to compressor discharge connection and well insulated)
Start-Stop Interval	See Notes

Performance Condition:

Condition	Condition Description
a	Rated Condition
b	Max. Load Condition, 90% Rated Voltage
c	Rated Condition, A Weighted Sound Power
d	Rated Condition, Max Operating Normal Displacement of Compressor Housing
e	Discharge Pressure and Suction Pressure: Saturated Refrigerant Pressure at 40°C
f	Max. Load Condition

2. Rated Condition, 48 Hours Break-in-Running before implementing Performance and Sound Testing

Item	Rated Condition	Max. Load Condition
E.T.(°C)/C.T.(°C)/S.H.(K)/ S.C.(K)/A.T.(°C)	-31.6/40.6/36/0/35	0/60/20/0/46.1
Cooling Capacity Deviation	≥90.0%	-
Power Deviation	≤110.0%	-
COP Deviation	≥90.0%	-

3. Internal Protector

Protection Method	Config	Parameter		
Internal Overload Protector	With	Vendor	Vendor 1	Vendor 2
		Model	UP28LA05B-XX	
		Open Temp.(°C)	125±5	
		Close Temp. (°C)	70±10	
		Short Time Trip	103A 3-10s	A S
Internal Pressure Relieve Valve	Without	2.76-3.10MPa		

4. Accessory

Item	Name	P.N.	PCS
1	Grommet	070-0003-00	4
2	Sleeve	010-0014-00	4
3	TREV	100-0002-01	1

5. Compressor Operating Envelope

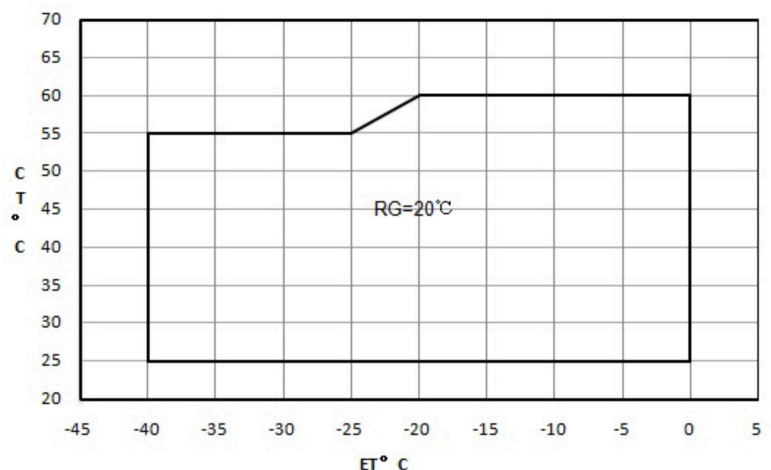

Compressor Performance Sheet

- » Performance Based on Superheat is within the Operating Envelope, Subcooling after Condenser is OK;
- » Performance Calculated by Coefficients of Polynomial is Only Suitable for the Condition within Operating Envelope
- » Capacity, Power can be Calculated by Coefficients of Polynomial

Performance Table

Item	E.T.(°C) C.T.(°C)	Temperature (°C)								
		-40	-35	-30	-25	-20	-15	-10	-5	0
Cooling Cap. (W)	60					5408	6588	8010	9721	11768
	55	2319	3064	3877	4803	5892	7189	8742	10598	12804
	50	2503	3299	4175	5181	6362	7766	9440	11432	13788
	45	2703	3538	4470	5544	6808	8309	10095	12213	14709
	40	2907	3773	4749	5882	7220	8809	10697	12930	15557
	35	3106	3993	5004	6186	7587	9254	11233	13573	16320
	30	3289	4186	5222	6444	7899	9633	11695	14131	16989
	25	3445	4343	5395	6646	8144	9937	12071	14594	17552
	20	3588	4500	5570	6844	8444	10337	12611	15374	18400
Power (W)	60					5947	6118	6308	6492	6643
	55	5061	4947	4947	5034	5183	5368	5563	5742	5879
	50	4320	4252	4288	4403	4569	4762	4954	5121	5236
	45	3729	3700	3766	3900	4077	4270	4453	4601	4687
	40	3261	3265	3353	3500	3680	3867	4034	4156	4206
	35	2890	2919	3023	3176	3352	3525	3669	3758	3766
	30	2588	2636	2749	2901	3066	3218	3332	3381	3339
	25	2330	2389	2503	2647	2794	2919	2996	2998	2899
	20	2110	2170	2290	2420	2550	2650	2700	2700	2600

Ten Coefficients of Polynomial

Expression	$z = p_0 + p_1x + p_2y + p_3x^2 + p_4xy + p_5y^2 + p_6x^3 + p_7x^2y + p_8xy^2 + p_9y^3$		
Description	z: Cooling Capacity(W) or Power (W) Specially: Heating Capacity(W)=Cooling Capacity(W)+Power (W) x: E.T. °C y: C.T. °C p0~p9: Coefficients of Polynomial		
Cooling Cap. Factor	Value	Power Factor	Value
p0	18423.54439	p0	-434.30118
p1	716.981532	p1	-113.892396
p2	40.55574	p2	198.026496
p3	11.08494	p3	-3.499308
p4	-2.160756	p4	3.995724
p5	-3.367176	p5	-3.48222
p6	0.062904	p6	-0.034632
p7	-0.057	p7	0.038868
p8	-0.039228	p8	-0.027924
p9	0.01404	p9	0.035796

Notes: Coefficients of polynomial are based on the fitting results of some sample data, which can be used as a reference of compressor selection, but cannot completely eliminate customer's test.

Drawings
Outline Drawing

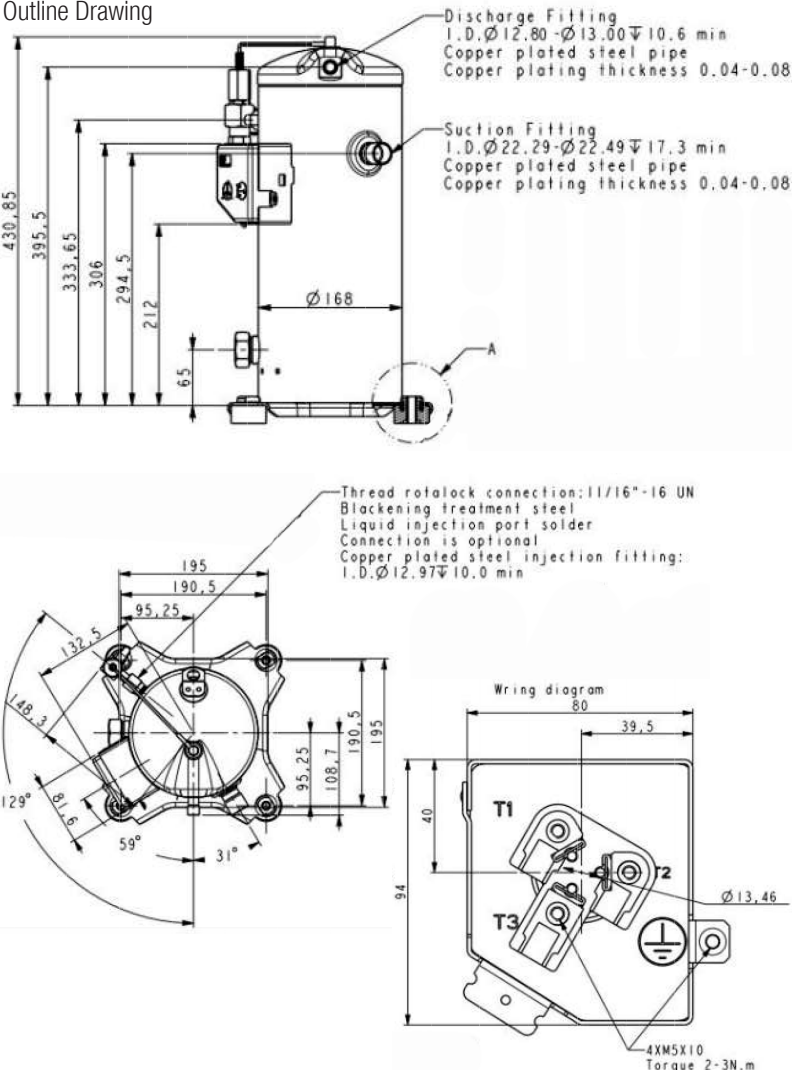

Notes

- It is not allowed to perform vacuum in the system by using the refrigeration compressor. The compressor can start only after the refrigerant charged. In some cases, such as on the field site, if it is limited by the situation that can't charge the required volume of refrigerant, 50% of the required refrigerant is charged necessary before the compressor starts. Double check the system and make sure everything is under safe status, then power on the compressor and charge the remained refrigerant when the compressor is running.
- It is not allowed to charge the refrigerant from the suction or discharge line closes to the compressor. The charge port should be arranged on the connection pipe of suction line accumulator or receiver, which is on the side far away to the compressor, to avoid the liquid refrigerant flood back.
- Refrigerant charge limitation: the ratio between the weight of oil and refrigerant should be ≥ 0.4 .
- It is not allowed to vacuum by compressor, not allowed to run the compressor without refrigerant, and not allowed to run the compressor on the reversed direction for long duration.
- The compressor can only work with approved refrigerant.
- The compressor is not allowed to work outside its envelope, the system should guarantee the suction line superheat and avoid the liquid refrigerant flood back.
- When the suction and discharge plugs are removed, the assembly and brazing should be done in 15 minutes.
- The frequently start/stop should be avoided. The suggested minimum continuous running time is 10 minutes to guarantee the safe oil level ($\geq 50\%$ initial charge volume), the suggested minimum interval duration between start and stop is 3 minutes.
- The deviation of supplied voltage should be less than $\pm 10\%$ of rated voltage.
- A 70W crankcase heater is recommended to avoid the refrigerant migration during the off circle and flood start. The crankcase heater should be power on 12 hours earlier than the first start or restart after long duration off.
- The system should be equipped with necessary protection devices, such as pressure, temperature, oil return, overcurrent and phase fault, etc.
- The compressor is not allowed to lay down or place upside down during transportation, stock and installation. The maximum inclination is 15° when the compressor is running.

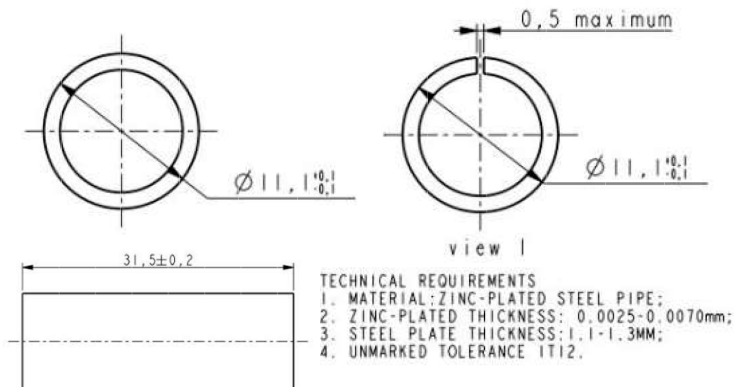
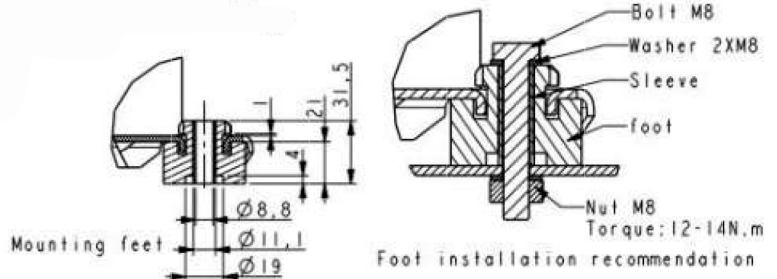

Grommet Drawing

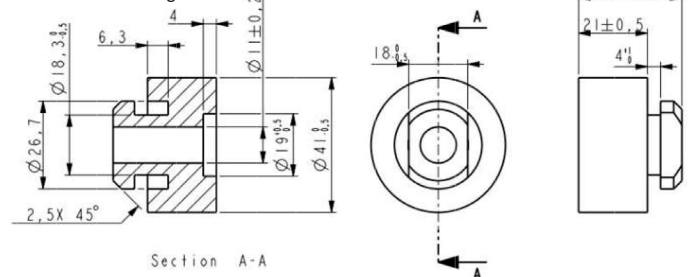

Single Phase Compressor Wiring Diagram
Only for single phase

Application

- See Details in the YF serial LBP refrigerant scroll compressor application manual