

Basic Specification	
Model	YF41E7S-Q100 (Including Extended Model)
Type	Low Side Shell Design Scroll Compressor
Application	Refrigeration
Power	6 HP
Capacity (BTU/Hr)	16590
Refrigerant	R448A/R449A
Displacement(cc/rev)	98.3
Cooling Capacity(W) <sup>(a)</sup>	4861
Input Power(W) <sup>(a)</sup>	3871
RLA(A) <sup>(a)</sup>	12.2
Cooling COP(W/W) <sup>(a)</sup>	1.26
Power Supply	208-230V/3~/60Hz
Min. Operating Voltage(V)	187
Max. Operating Voltage(V)	253
LRA(A)	167
Max. Operating Current(A) <sup>(b)</sup>	22.5
Rated Speed(r/min) <sup>(a)</sup>	3500
Compressor Weight (With Oil)(kg)	33
Oil Type	POE
Oil Kinematic Viscosity(cSt, 40°C)	32
Oil Density(kg/L, 20°C)	0.977
Primary Charge(L)	1.6
Recharge(L)	1.45
Oil Circulation Rate <sup>(a)</sup>	≤1%
Rated Sound(Sound Power)(dBA) <sup>(c)</sup>	76
Max. Operating Sound in Running Envelope (Sound Power)(dBA)	81
Vibration Displacement Peak-Peak(mm) <sup>(d)</sup>	≤0.1
Moisture(mg)	≤500
Impurity(mg)	≤100
LVS(V) <sup>(e)</sup>	177
MOV (V) <sup>(f)</sup>	187
Start Capacitor(μF/V)	/
Start Relay	/
Run Capacitor(μF/V)	/
IP Class of Terminal Box	IP21
Compressor Color	Black

Motor Parameters	
Motor Type	Three-phase asynchronous motor
Motor Pole	2
Motor Insulation Class(°C)	130(B Class)
Line to Line Resistance UV(CS)(Ω, 25°C)	0.44(±10%)
Line to Line Resistance UW(CR)(Ω, 25°C)	0.44(±10%)
Line to Line Resistance VW(SR)(Ω, 25°C)	0.44(±10%)
Dielectric Strength	2000VAC / 1s / 60Hz, Leakage Current≤5mA
Insulation Resistance(MΩ)	≥20
Ground Resistance(Ω)	≤0.1

Safety Operating Limit	
Tightness Test Pressure (MPa)	3.8-4.0
Max. Operating Pressure	
High Side(MPa) Low Side(MPa)	H3.2/L2.0
Compressor FreeSpace(Without Oil)	
High Side(L) Low Side(L)	H1.0/L4.2
Max. Refrigerant Charge(kg)	See Notes
Discharge Temperature Limit(°C)	≤120 (120mm to compressor discharge connection and well insulated)
Start-Stop Interval	See Notes

Performance Condition:

Condition	Condition Description
a	Rated Condition
b	Max. Load Condition, 90% Rated Voltage
c	Rated Condition, A Weighted Sound Power
d	Rated Condition, Max Operating Normal Displacement of Compressor Housing
e	Discharge Pressure and Suction Pressure: Saturated Refrigerant Pressure at 40°C
f	Max. Load Condition

2. Rated Condition, 48 Hours Break-in-Running before implementing Performance and Sound Testing

Item	Rated Condition	Max. Load Condition
E.T.(°C)/C.T.(°C)/S.H.(K)/ S.C.(K)/A.T.(°C)	-31.6/40.6/36/0/35	0/60/20/0/46.1
Cooling Capacity Deviation	≥90.0%	-
Power Deviation	≤110.0%	-
COP Deviation	≥90.0%	-

3. Internal Protector

Protection Method	Config	Parameter		
		Vendor	Vendor 1	Vendor 2
Internal Overload Protector	With	Model	UP28MA03B-XX	
		Open Temp.(°C)	130±5	
		Close Temp. (°C)	70±10	
		Short Time Trip	112A 3-10s	A S
		Internal Pressure Relieve Valve	Without	2.76-3.10MPa

4. Accessory

Item	Name	P.N.	PCS
1	Grommet	070-0003-00	4
2	Sleeve	010-0014-00	4
3	TREV	100-0002-01	1

5. Compressor Operating Envelope

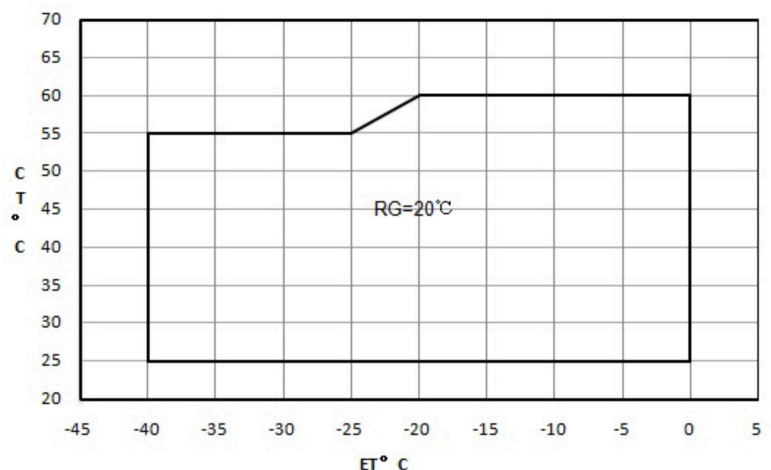

Compressor Performance Sheet

- » Performance Based on Superheat is within the Operating Envelope, Subcooling after Condenser is OK;
- » Performance Calculated by Coefficients of Polynomial is Only Suitable for the Condition within Operating Envelope
- » Capacity, Power can be Calculated by Coefficients of Polynomial

Performance Table										
Item	E.T.°C C.T.°C	-40	-35	-30	-25	-20	-15	-10	-5	0
Cooling Cap. (CW)	60					6382	7775	9453	11471	13887
	55	2737	3616	4575	5668	6952	8483	10316	12506	15110
	50	2954	3893	4927	6113	7507	9164	11140	13491	16271
	45	3190	4176	5274	6542	8034	9806	11913	14412	17358
	40	3431	4453	5605	6942	8520	10395	12623	15259	18358
	35	3666	4712	5905	7300	8953	10920	13256	16017	19259
	30	3881	4940	6163	7604	9321	11368	13801	16676	20048
Power (W)	25	4065	5125	6366	7843	9611	11726	14245	17222	20713
	60					7018	7219	7444	7661	7839
	55	5972	5838	5837	5941	6117	6335	6565	6776	6938
	50	5097	5018	5060	5195	5392	5619	5846	6043	6179
	45	4400	4366	4444	4603	4811	5039	5255	5430	5531
	40	3848	3853	3957	4131	4343	4563	4760	4904	4964
	35	3410	3445	3568	3748	3956	4160	4330	4434	4444
30	3054	3111	3244	3423	3618	3798	3932	3990	3940	
25	2749	2819	2954	3124	3298	3445	3535	3537	3421	

Ten Coefficients of Polynomial			
Expression	$z = p_0 + p_1x + p_2y + p_3x^2 + p_4xy + p_5y^2 + p_6x^3 + p_7x^2y + p_8xy^2 + p_9y^3$		
Description	z: Cooling Capacity(W) or Power (W) Specially: Heating Capacity(W)=Cooling Capacity(W)+Power (W) x: E.T. °C y: C.T. °C p0~p9: Coefficients of Polynomial		
Cooling Cap. Factor	Value	Power Factor	Value
p0	21741.10941	p0	-512.5066746
p1	846.0898511	p1	-134.4012308
p2	47.85869438	p2	233.6855289
p3	13.08102764	p3	-4.129435491
p4	-2.54984772	p4	4.715242127
p5	-3.97351021	p5	-4.10927042
p6	0.074231251	p6	-0.040868255
p7	-0.06726411	p7	0.04586704
p8	-0.04629187	p8	-0.032952331
p9	0.016568211	p9	0.042241858

Notes: Coefficients of polynomial are based on the fitting results of some sample data, which can be used as a reference of compressor selection, but cannot completely eliminate customer's test.

**Drawings**  
Outline Drawing

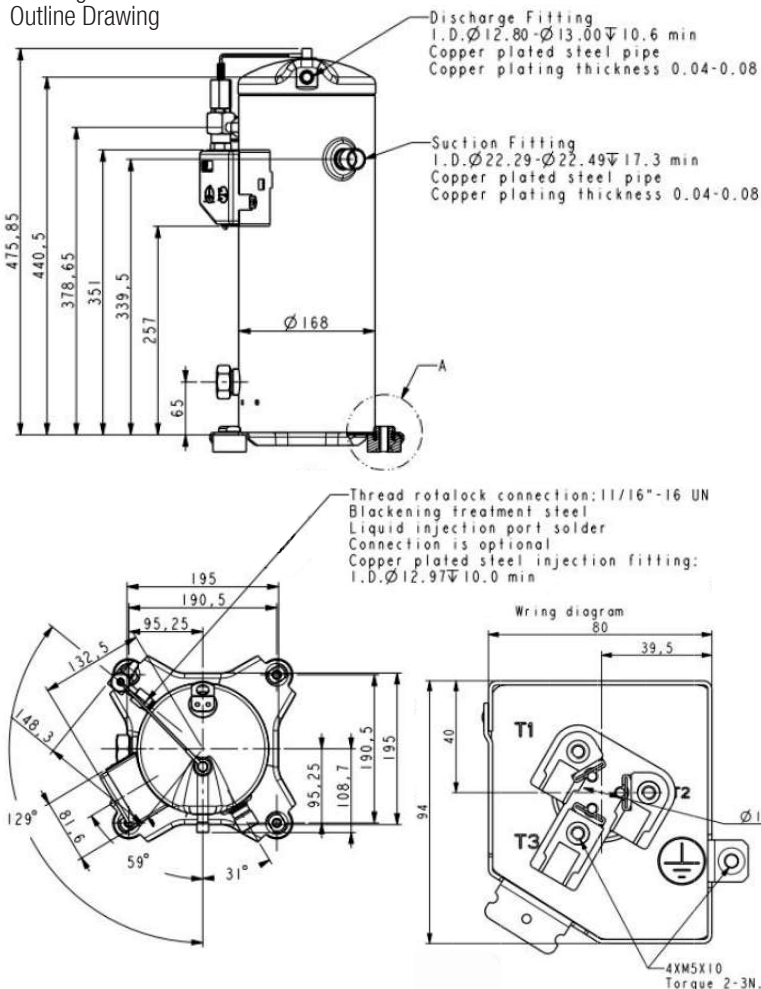

**Notes**

- It is not allowed to perform vacuum in the system by using the refrigeration compressor. The compressor can start only after the refrigerant charged. In some cases, such as on the field site, if it is limited by the situation that can't charge the required volume of refrigerant, 50% of the required refrigerant is charged necessary before the compressor starts. Double check the system and make sure everything is under safe status, then power on the compressor and charge the remained refrigerant when the compressor is running.
- It is not allowed to charge the refrigerant from the suction or discharge line closes to the compressor. The charge port should be arranged on the connection pipe of suction line accumulator or receiver, which is on the side far away to the compressor, to avoid the liquid refrigerant flood back.
- Refrigerant charge limitation: the ratio between the weight of oil and refrigerant should be  $\geq 0.4$ .
- It is not allowed to vacuum by compressor, not allowed to run the compressor without refrigerant, and not allowed to run the compressor on the reversed direction for long duration.
- The compressor can only work with approved refrigerant.
- The compressor is not allowed to work outside its envelope, the system should guarantee the suction line superheat and avoid the liquid refrigerant flood back.
- When the suction and discharge plugs are removed, the assembly and brazing should be done in 15 minutes.
- The frequently start/stop should be avoided. The suggested minimum continuous running time is 10 minutes to guarantee the safe oil level ( $\geq 50\%$  initial charge volume), the suggested minimum interval duration between start and stop is 3 minutes.
- The deviation of supplied voltage should be less than  $\pm 10\%$  of rated voltage.
- A 70W crankcase heater is recommended to avoid the refrigerant migration during the off circle and flood start. The crankcase heater should be power on 12 hours earlier than the first start or restart after long duration off.
- The system should be equipped with necessary protection devices, such as pressure, temperature, oil return, overcurrent and phase fault, etc.
- The compressor is not allowed to lay down or place upside down during transportation, stock and installation. The maximum inclination is  $15^\circ$  when the compressor is running.

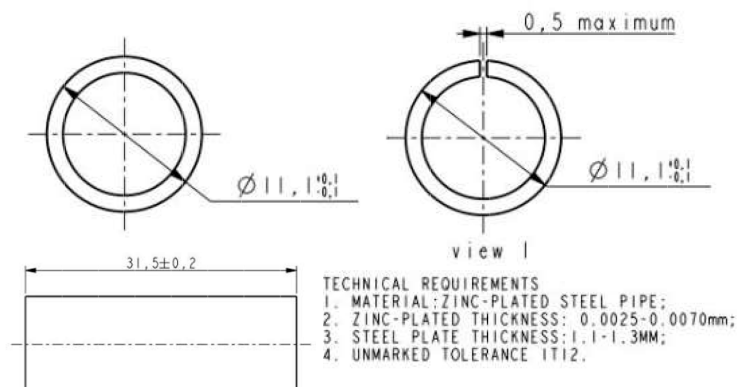
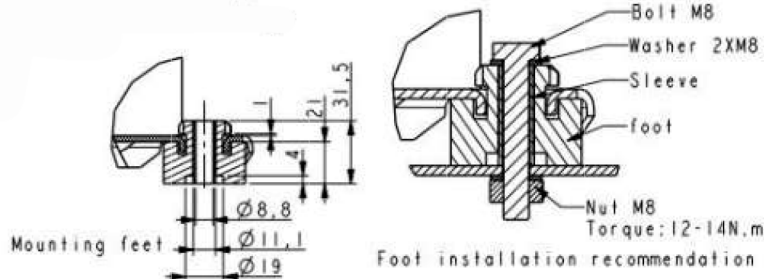

**Grommet Drawing**

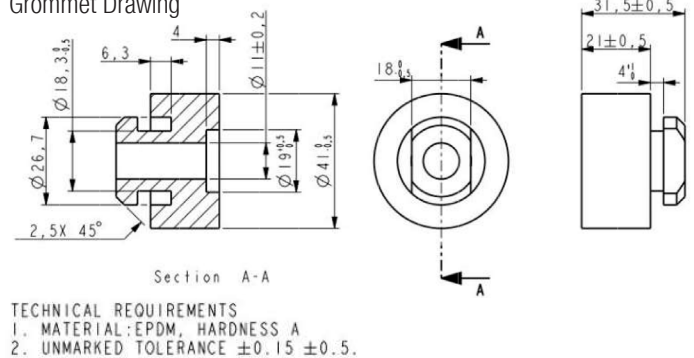

**Single Phase Compressor Wiring Diagram**  
Only for single phase

**Application**

- See Details in the YF serial LBP refrigerant scroll compressor application manual