

Basic Specification	
Model	YM158E7S-100 (Including Extended Models)
Type	Low Side Shell Design Scroll Compressor
Application	Medium Temp. Refrigeration
Power	9 HP
Capacity (BTU/Hr)	65520
Refrigerant	R448A/R449A
Displacement(cc/rev)	145.4
Cooling Capacity(W) <sup>(a)</sup>	19203
Input Power(W) <sup>(a)</sup>	8740
RLA(A) <sup>(a)</sup>	29.6
Cooling COP(W/W) <sup>(a)</sup>	2.2
Power Supply	208-230V/3~/60Hz
Min. Operating Voltage(V)	187
Max. Operating Voltage(V)	253
LRA(A)	241
Max. Operating Current(A) <sup>(b)</sup>	43.6
Rated Speed(r/min) <sup>(a)</sup>	3500
Compressor Weight (With Oil)(kg)	53
Oil Type	POE
Oil Kinematic Viscosity (cSt, 40°C)	32
Oil Density (kg/L, 20°C)	0.977
Primary Charge(L)	2.7
Recharge(L)	2.55
Oil Circulation Rate <sup>(a)</sup>	≤1%
Rated Sound (Sound Power)(dBA) <sup>(c)</sup>	78
Max. Operating Sound in Running Envelope (Sound Power)(dBA)	83
Vibration Displacement Peak-Peak (mm) <sup>(d)</sup>	≤0.12
Moisture (mg)	≤1100
Impurity (mg)	≤140
LVS(V) <sup>(e)</sup>	177
MOV (V) <sup>(f)</sup>	187
Start Capacitor (μF/V)	/
Start Relay	/
Run Capacitor (μF/V)	/
IP Class of Terminal Box	IP54
Compressor Color	Black

Motor Parameters	
Motor Type	Three-phase asynchronous motor
Motor Pole	2
Motor Insulation Class(°C)	130(B Class)
Line to Line Resistance UV(CS)(Ω, 25°C)	0.258( ± 10%)
Line to Line Resistance UW(CR)(Ω, 25°C)	0.258( ± 10%)
Line to Line Resistance VW(SR)(Ω, 25°C)	0.258( ± 10%)
Dielectric Strength	2000VAC / 1s / 60Hz, Leakage Current≤5mA
Insulation Resistance(MΩ)	≥20
Ground Resistance(Ω)	≤0.1

Safety Operating Limit	
Tightness Test Pressure (MPa)	3.8-4.0
Max. Operating Pressure	
High Side(MPa) Low Side(MPa)	H3.2/L2.0
Compressor FreeSpace(Without Oil)	
High Side(L) Low Side(L)	H0.9/L6.5
Max. Refrigerant Charge(kg)	See Notes
Discharge Temperature Limit(°C)	≤125 (120mm to compressor discharge connection and well insulated)
Start-Stop Interval	See Notes

Performance Condition:

Condition	Condition Description
a	Rated Condition
b	Max. Load Condition, 90% Rated Voltage
c	Rated Condition, A Weighted Sound Power
d	Rated Condition, Max Operating Normal Displacement of Compressor Housing
e	Discharge Pressure and Suction Pressure: Saturated Refrigerant Pressure at 40°C
f	Max. Load Condition

2. Rated Condition, 48 Hours Break-in-Running before implementing Performance and Sound Testing

Item	Rated Condition	Max. Load Condition
E.T.(°C)/C.T.(°C)/S.H.(K)/ S.C.(K)/A.T.(°C)	-6.7/48.9/11.1/0/35	10/65/11.9/0/46.1
Cooling Capacity Deviation	≥92.5%	-
Power Deviation	≤107.5%	-
COP Deviation	≥92.5%	-

3. Internal Protector

Protection Method	Config	Parameter		
Internal Overload Protector	With	Vendor	Vendor 1	Vendor 2
		Model	UP28NA03B-XX	
		Open Temp.(°C)	135±5	
		Close Temp. (°C)	70±10	
		Short Time Trip	120A 3-10s	A S
Internal Pressure Relieve Valve	With	2.76-3.10MPa		

4. Accessory

Item	Name	P.N.	PCS
1	Grommet	070-0003-00	4
2	Sleeve	010-0014-00	4

5. Compressor Operating Envelope

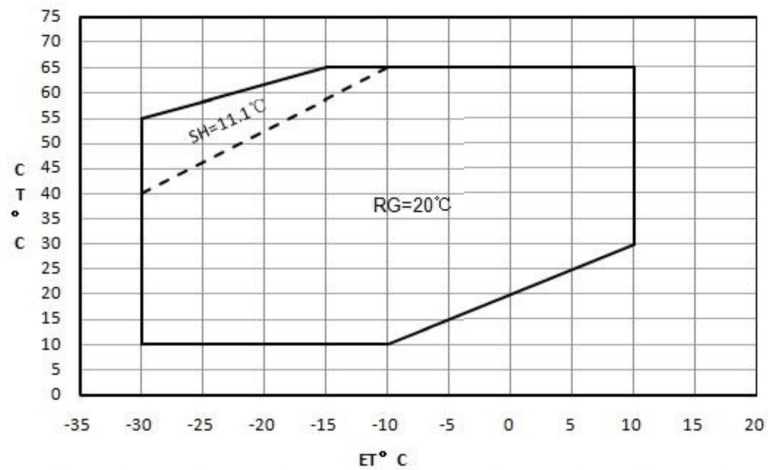

Compressor Performance Sheet

- » Performance Based on Superheat is within the Operating Envelope, Subcooling after Condenser is 0K;
- » Performance Calculated by Coefficients of Polynomial is Only Suitable for the Condition within Operating Envelope
- » Capacity, Power can be Calculated by Coefficients of Polynomial

Performance Table										
Item	Efficiency (%)	-30	-25	-20	-15	-10	-5	0	5	10
Cooling Cap. (W)	65					13082	15817	19062	22828	27122
	60				11807	14339	17400	21000	25148	29853
	55			10484	12742	15548	18911	22842	27349	32441
	50		9264	11176	13656	16713	20355	24593	29435	34890
	45	8296	9793	11876	14554	17838	21735	26256	31410	37205
	40	8741	10357	12587	15440	18927	23056	27836	33277	39388
	35	9249	10959	13312	16317	19984	24320	29336	35042	41445
	30	9823	11604	14057	17190	21012	25532	30761	36706	43378
	25	10467	12296	14825	18061	22015	26696	32113	38275	
	20	11185	13038	15619	18936	22998	27816	33397		
10	12859	14689	17302	20709	24917					
Power (W)	65					10958	11542	12066	12570	13095
	60				9564	10154	10656	11112	11561	12044
	55			8261	8883	9391	9825	10225	10633	11087
	50		7010	7692	8232	8672	9050	9408	9786	10225
	45	5774	6542	7141	7613	7996	8332	8661	9024	9460
	40	5394	6080	6610	7025	7366	7673	7986	8346	8792
	35	5009	5625	6099	6472	6783	7073	7383	7753	8223
	30	4619	5178	5610	5952	6247	6535	6854	7247	7754
	25	4225	4742	5143	5469	5761	6058	6401	6830	
	20	3830	4316	4700	5023	5324	5644	6023		
10	3037	3502	3892	4246	4605					

Ten Coefficients of Polynomial			
Expression	$z = p_0 + p_1*x + p_2*y + p_3*x^2 + p_4*x*y + p_5*y^2 + p_6*x^3 + p_7*x^2*y + p_8*x*y^2 + p_9*y^3$		
Description	z: Cooling Capacity (W) or Power (W) Specially: Heating Capacity (W) = Cooling Capacity (W) + Power (W) x: E.T. °C y: C.T. °C p0~p9: Coefficients of Polynomial		
Cooling Cap. Factor	Value	Power Factor	Value
p0	37927.071905	p0	5295.822455
p1	1288.873178	p1	144.714165
p2	-204.835971	p2	4.201244
p3	17.718457	p3	3.052665
p4	-2.881335	p4	-4.058177
p5	-0.981285	p5	1.638061
p6	0.012306	p6	0.053798
p7	-0.112617	p7	-0.053049
p8	-0.094862	p8	0.052196
p9	-0.005114	p9	-0.001542

Notes: Coefficients of polynomial are based on the fitting results of some sample data, which can be used as a reference of compressor selection, but cannot completely eliminate customer's test.

Grommet Drawing

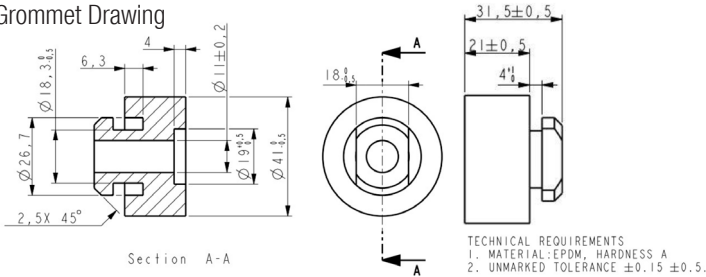

Sleeve Drawing

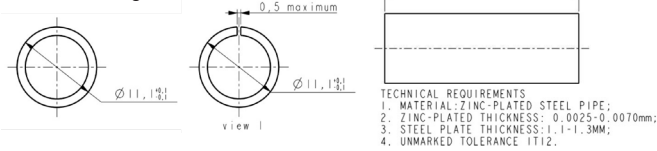

T-Box Layout Standard

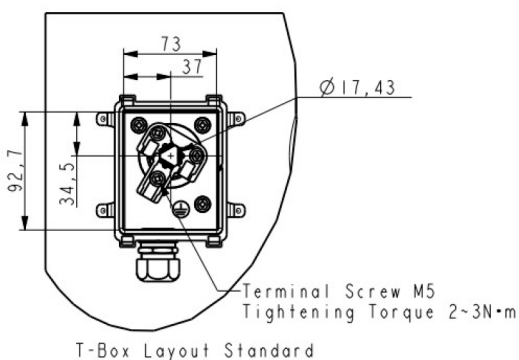

Notes

- » It is not allowed to perform vacuum in the system by using the refrigeration compressor. The compressor can start only after the refrigerant charged. In some cases, such as on the field site, if it is limited by the situation that can't charge the required volume of refrigerant, 50% of the required refrigerant is charged necessary before the compressor starts. Double check the system and make sure everything is under safe status, then power on the compressor and charge the remained refrigerant when the compressor is running.
- » It is not allowed to charge the refrigerant from the suction or discharge line closes to the compressor. The charge port should be arranged on the connection pipe of suction line accumulator or receiver, which is on the side far away to the compressor, to avoid the liquid refrigerant flood back.
- » Refrigerant charge limitation: the ratio between the weight of oil and refrigerant should be >=0.4.
- » It is not allowed to vacuum by compressor, not allowed to run the compressor without refrigerant, and not allowed to run the compressor on the reversed direction for long duration.
- » The compressor can only work with approved refrigerant.
- » The compressor is not allowed to work outside its envelope, the system should guarantee the suction line superheat and avoid the liquid refrigerant flood back.
- » When the suction and discharge plugs are removed, the assembly and brazing should be done in 15 minutes.
- » The frequently start/stop should be avoided. The suggested minimum continuous running time is 10 minutes to guarantee the safe oil level (>=50% initial charge volume), the suggested minimum interval duration between start and stop is 3 minutes.
- » The deviation of supplied voltage should be less than +/-10% of rated voltage.
- » A 90W crankcase heater is recommended to avoid the refrigerant migration during the off circle and flood start. The crankcase heater should be power on 12 hours earlier than the first start or restart after long duration off.
- » The system should be equipped with necessary protection devices, such as pressure, temperature, oil return, overcurrent and phase fault, etc.
- » The compressor is not allowed to lay down or place upside down during transportation, stock and installation. The maximum inclination is 15° when the compressor is running.

Drawings

Outline Drawing

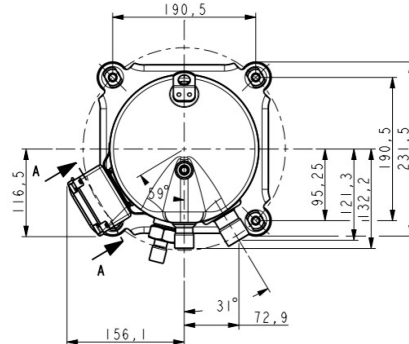
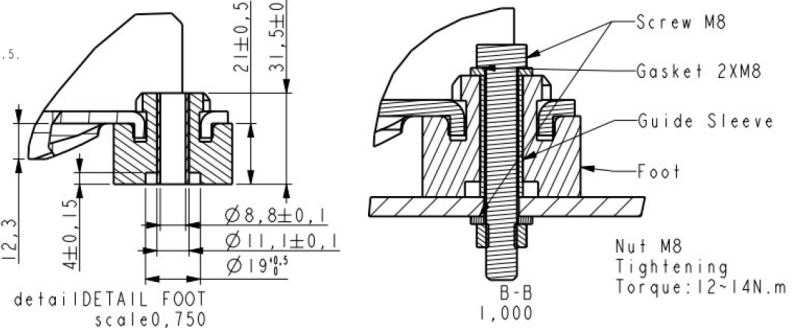
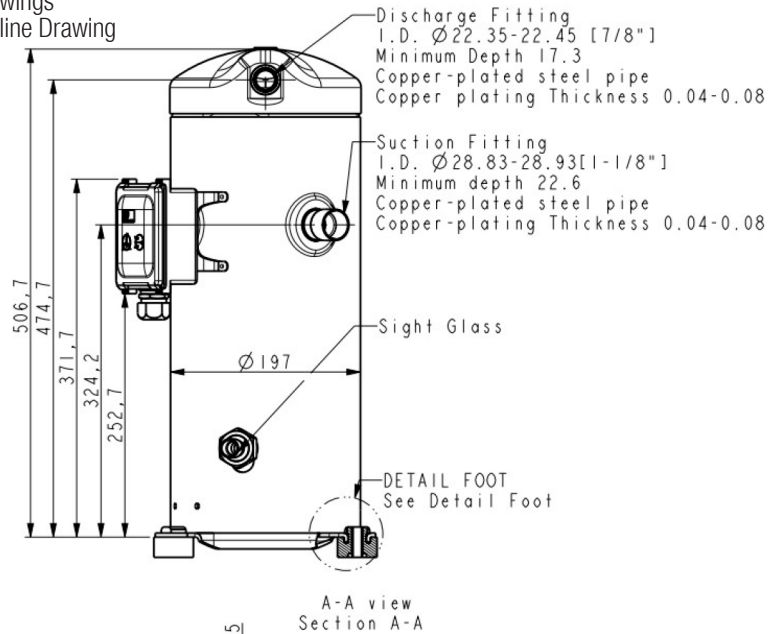

Application

- » See Details in the YM serial MBP refrigerant scroll compressor application manual

- » Single Phase Compressor Wiring Diagram  
Only for single phase