

Basic Specification	
Model	YM182E7G-100 (Including Extended Models)
Type	Low Side Shell Design Scroll Compressor
Application	Medium Temp. Refrigeration
Power	10 HP
Capacity (BTU/Hr)	73852
Refrigerant	R448A/R449A
Displacement(cc/rev)	167.2
Cooling Capacity(W) ^(a)	21645
Input Power(W) ^(a)	9851
RLA(A) ^(a)	33.3
Cooling COP(W/W) ^(a)	2.2
Power Supply	208-230V/3~/60Hz
Min. Operating Voltage(V)	187
Max. Operating Voltage(V)	253
LRA(A)	290
Max. Operating Current(A) ^(b)	49.2
Rated Speed(r/min) ^(a)	3500
Compressor Weight (With Oil)(kg)	54
Oil Type	POE
Oil Kinematic Viscosity (cSt, 40°C)	32
Oil Density (kg/L, 20°C)	0.977
Primary Charge(L)	2.7
Recharge(L)	2.55
Oil Circulation Rate ^(a)	≤1%
Rated Sound (Sound Power)(dBA) ^(c)	79
Max. Operating Sound in Running Envelope (Sound Power)(dBA)	84
Vibration Displacement Peak-Peak (mm) ^(d)	≤0.12
Moisture (mg)	≤1500
Impurity (mg)	≤180
LVS(V) ^(e)	177
MOV (V) ^(f)	187
Start Capacitor (μF/V)	/
Start Relay	/
Run Capacitor (μF/V)	/
IP Class of Terminal Box	IP54
Compressor Color	Black

Motor Parameters	
Motor Type	Three-phase asynchronous motor
Motor Pole	2
Motor Insulation Class(°C)	130(B Class)
Line to Line Resistance UV(CS)(Ω, 25°C)	0.258(± 10%)
Line to Line Resistance UW(CR)(Ω, 25°C)	0.258(± 10%)
Line to Line Resistance VW(SR)(Ω, 25°C)	0.258(± 10%)
Dielectric Strength	2000VAC / 1s / 60Hz, Leakage Current≤5mA
Insulation Resistance(MΩ)	≥20
Ground Resistance(Ω)	≤0.1

Safety Operating Limit	
Tightness Test Pressure (MPa)	3.8-4.0
Max. Operating Pressure	
High Side(MPa) Low Side(MPa)	H3.2/L2.0
Compressor FreeSpace(Without Oil)	
High Side(L) Low Side(L)	H0.9/L6.3
Max. Refrigerant Charge(kg)	See Notes
Discharge Temperature Limit(°C)	≤125 (120mm to compressor discharge connection and well insulated)
Start-Stop Interval	See Notes

Performance Condition:

Condition	Condition Description
a	Rated Condition
b	Max. Load Condition, 90% Rated Voltage
c	Rated Condition, A Weighted Sound Power
d	Rated Condition, Max Operating Normal Displacement of Compressor Housing
e	Discharge Pressure and Suction Pressure: Saturated Refrigerant Pressure at 40°C
f	Max. Load Condition

2. Rated Condition, 48 Hours Break-in-Running before implementing Performance and Sound Testing

Item	Rated Condition	Max. Load Condition
E.T.(°C)/C.T.(°C)/S.H.(K)/ S.C.(K)/A.T.(°C)	-6.7/48.9/11.1/0/35	10/65/11.9/0/46.1
Cooling Capacity Deviation	≥92.5%	-
Power Deviation	≤107.5%	-
COP Deviation	≥92.5%	-

3. Internal Protector

Protection Method	Config	Parameter		
Internal Overload Protector	With	Vendor	Vendor 1	Vendor 2
		Model	UP9NY0506-XX	
		Open Temp.(°C)	135±5	
		Close Temp. (°C)	60±9	
		Short Time Trip	174A 3-10s	A S
Internal Pressure Relieve Valve	With	2.76-3.10MPa		

4. Accessory

Item	Name	P.N.	PCS
1	Grommet	070-0003-00	4
2	Sleeve	010-0014-00	4

5. Compressor Operating Envelope

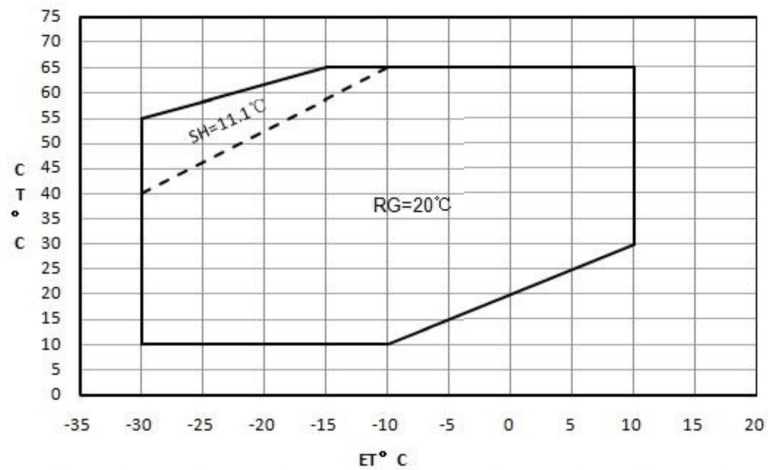

Compressor Performance Sheet

- » Performance Based on Superheat is within the Operating Envelope, Subcooling after Condenser is 0K;
- » Performance Calculated by Coefficients of Polynomial is Only Suitable for the Condition within Operating Envelope
- » Capacity, Power can be Calculated by Coefficients of Polynomial

Performance Table											
Item	E.T. °C	C.T. °C	-30	-25	-20	-15	-10	-5	0	5	10
Cooling Cap. (W)	65						14783	17873	21540	25795	30648
	60					13342	16203	19662	23730	28417	33734
	55				11847	14398	17569	21370	25811	30904	36658
	50		10468	12629	15431	18885	23001	27790	33261	39426	
	45	9375	11066	13420	16446	20157	24561	29670	35493	42041	
	40	9878	11703	14223	17447	21387	26053	31455	37603	44509	
	35	10451	12384	15043	18439	22582	27482	33150	39597	46832	
	30	11100	13113	15885	19425	23743	28852	34760	41478	49017	
	25	11828	13895	16752	20409	24877	30167	36288	43251		
	20	12639	14733	17649	21397	25988	31432	37739			
10	14531	16599	19552	23401	28156						
Power (W)	65					12328	12985	13574	14142	14732	
	60				10759	11423	11988	12501	13006	13549	
	55			9294	9994	10565	11053	11504	11962	12473	
	50		7887	8654	9261	9755	10181	10584	11010	11503	
	45	6496	7360	8034	8564	8996	9374	9744	10152	10642	
	40	6068	6840	7436	7904	8287	8632	8984	9389	9891	
	35	5635	6328	6861	7281	7631	7958	8306	8722	9251	
	30	5196	5826	6311	6697	7028	7351	7711	8153	8723	
	25	4753	5335	5786	6153	6481	6815	7201	7684		
	20	4309	4856	5288	5651	5989	6349	6776			
10	3417	3940	4378	4776	5181						

Ten Coefficients of Polynomial			
Expression	$z = p_0 + p_1*x + p_2*y + p_3*x^2 + p_4*x*y + p_5*y^2 + p_6*x^3 + p_7*x^2*y + p_8*x*y^2 + p_9*y^3$		
Description	z: Cooling Capacity(W) or Power (W) Specially: Heating Capacity(W)=Cooling Capacity(W)+Power (W) x: E.T. °C y: C.T. °C p0~p9: Coefficients of Polynomial		
Cooling Cap. Factor	Value	Power Factor	Value
p0	42857.591253	p0	5957.800262
p1	1456.426691	p1	162.803435
p2	-231.464648	p2	4.7264
p3	20.021856	p3	3.434248
p4	-3.255908	p4	-4.565449
p5	-1.108852	p5	1.842819
p6	0.013906	p6	0.060523
p7	-0.127257	p7	-0.059681
p8	-0.107194	p8	0.05872
p9	-0.005779	p9	-0.001735

Notes: Coefficients of polynomial are based on the fitting results of some sample data, which can be used as a reference of compressor selection, but cannot completely eliminate customer's test.

Grommet Drawing

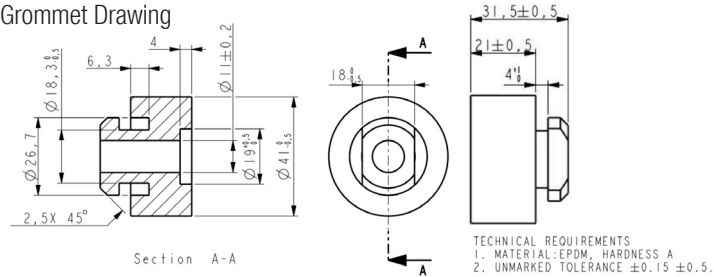

Sleeve Drawing

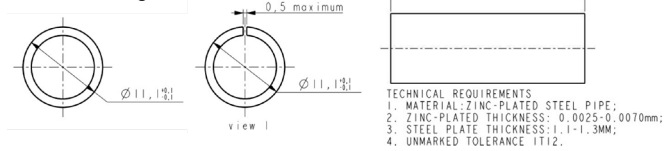

T-Box Layout Standard

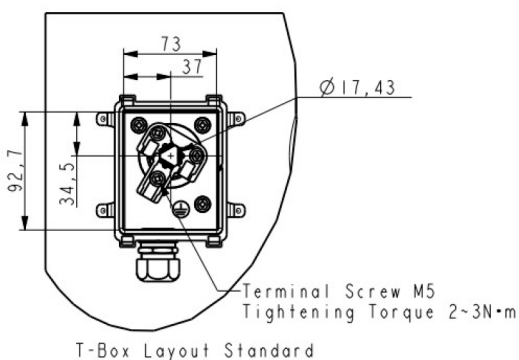

Notes

- » It is not allowed to perform vacuum in the system by using the refrigeration compressor. The compressor can start only after the refrigerant charged. In some cases, such as on the field site, if it is limited by the situation that can't charge the required volume of refrigerant, 50% of the required refrigerant is charged necessary before the compressor starts. Double check the system and make sure everything is under safe status, then power on the compressor and charge the remained refrigerant when the compressor is running.
- » It is not allowed to charge the refrigerant from the suction or discharge line closes to the compressor. The charge port should be arranged on the connection pipe of suction line accumulator or receiver, which is on the side far away to the compressor, to avoid the liquid refrigerant flood back.
- » Refrigerant charge limitation: the ratio between the weight of oil and refrigerant should be >=0.4.
- » It is not allowed to vacuum by compressor, not allowed to run the compressor without refrigerant, and not allowed to run the compressor on the reversed direction for long duration.
- » The compressor can only work with approved refrigerant.
- » The compressor is not allowed to work outside its envelope, the system should guarantee the suction line superheat and avoid the liquid refrigerant flood back.
- » When the suction and discharge plugs are removed, the assembly and brazing should be done in 15 minutes.
- » The frequently start/stop should be avoided. The suggested minimum continuous running time is 10 minutes to guarantee the safe oil level (>=50% initial charge volume), the suggested minimum interval duration between start and stop is 3 minutes.
- » The deviation of supplied voltage should be less than +/-10% of rated voltage.
- » A 90W crankcase heater is recommended to avoid the refrigerant migration during the off circle and flood start. The crankcase heater should be power on 12 hours earlier than the first start or restart after long duration off.
- » The system should be equipped with necessary protection devices, such as pressure, temperature, oil return, overcurrent and phase fault, etc.
- » The compressor is not allowed to lay down or place upside down during transportation, stock and installation. The maximum inclination is 15° when the compressor is running.

Drawings

Outline Drawing

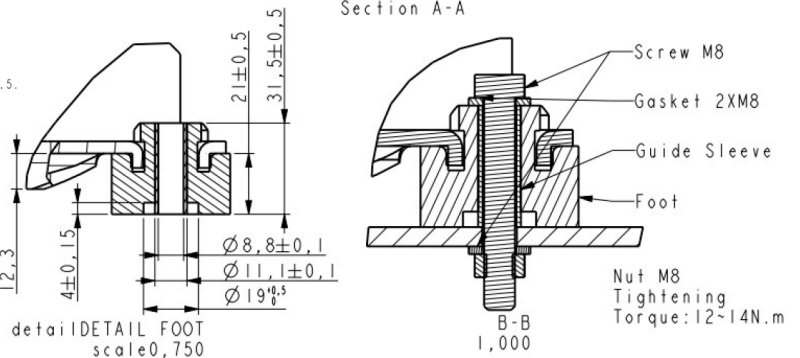
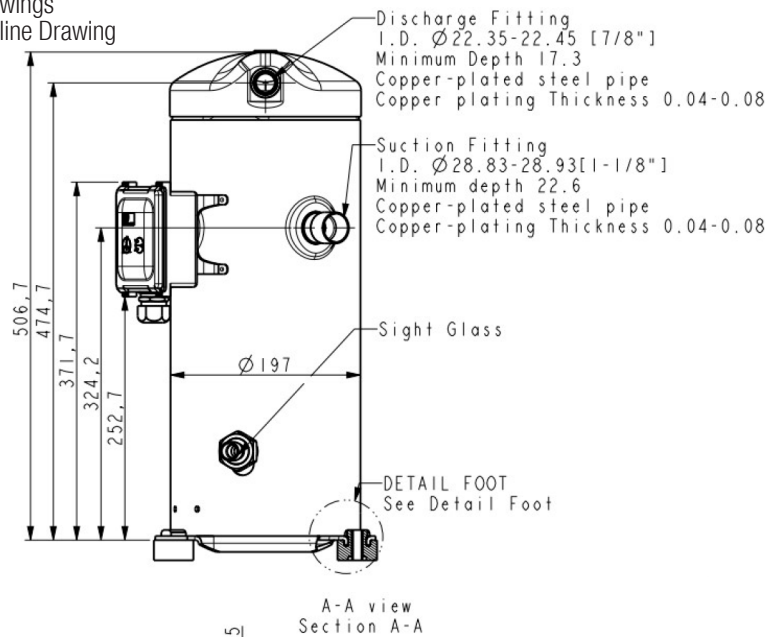

TECHNICAL REQUIREMENTS
1. ALL TOLERANCES UNLESS OTHERWISE SPECIFIED: ±2
2. TUBE ENDS MUST BE PLUGGED

Application

- » See Details in the YM serial MBP refrigerant scroll compressor application manual

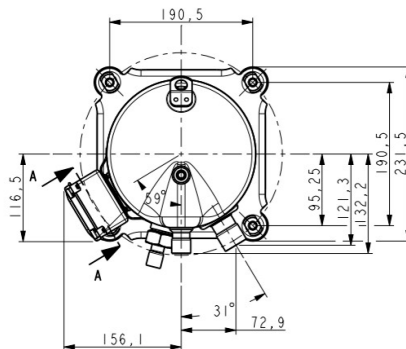

- » Single Phase Compressor Wiring Diagram
Only for single phase