

Basic Specification	
Model	YM210E7S-100 (Including Extended Models)
Type	Low Side Shell Design Scroll Compressor
Application	Medium Temp. Refrigeration
Power	13 HP
Capacity (BTU/Hr)	86650
Refrigerant	R448A/R449A
Displacement(cc/rev)	197.1
Cooling Capacity(W) ^(a)	25396
Input Power(W) ^(a)	11443
RLA(A) ^(a)	38.0
Cooling COP(W/W) ^(a)	2.22
Power Supply	208-230V/3~/60Hz
Min. Operating Voltage(V)	187
Max. Operating Voltage(V)	253
LRA(A)	290
Max. Operating Current(A) ^(b)	56.0
Rated Speed(r/min) ^(a)	3500
Compressor Weight (With Oil)(kg)	54
Oil Type	POE
Oil Kinematic Viscosity (cSt, 40°C)	32
Oil Density (kg/L, 20°C)	0.977
Primary Charge(L)	2.7
Recharge(L)	2.55
Oil Circulation Rate ^(a)	≤1%
Rated Sound (Sound Power)(dBA) ^(c)	81
Max. Operating Sound in Running Envelope (Sound Power)(dBA)	86
Vibration Displacement Peak-Peak (mm) ^(d)	≤0.12
Moisture (mg)	≤1500
Impurity (mg)	≤180
LVS(V) ^(e)	177
MOV (V) ^(f)	187
Start Capacitor (μF/V)	/
Start Relay	/
Run Capacitor (μF/V)	/
IP Class of Terminal Box	IP54
Compressor Color	Black

Motor Parameters	
Motor Type	Three-phase asynchronous motor
Motor Pole	2
Motor Insulation Class(°C)	130(B Class)
Line to Line Resistance UV(CS)(Ω, 25°C)	0.258(± 10%)
Line to Line Resistance UW(CR)(Ω, 25°C)	0.258(± 10%)
Line to Line Resistance VW(SR)(Ω, 25°C)	0.258(± 10%)
Dielectric Strength	2000VAC / 1s / 60Hz, Leakage Current≤5mA
Insulation Resistance(MΩ)	≥20
Ground Resistance(Ω)	≤0.1

Safety Operating Limit	
Tightness Test Pressure (MPa)	3.8-4.0
Max. Operating Pressure	
High Side(MPa) Low Side(MPa)	H3.2/L2.0
Compressor FreeSpace(Without Oil)	
High Side(L) Low Side(L)	H0.9/L6.3
Max. Refrigerant Charge(kg)	See Notes
Discharge Temperature Limit(°C)	≤125 (120mm to compressor discharge connection and well insulated)
Start-Stop Interval	See Notes

Performance Condition:

Condition	Condition Description
a	Rated Condition
b	Max. Load Condition, 90% Rated Voltage
c	Rated Condition, A Weighted Sound Power
d	Rated Condition, Max Operating Normal Displacement of Compressor Housing
e	Discharge Pressure and Suction Pressure: Saturated Refrigerant Pressure at 40°C
f	Max. Load Condition

2. Rated Condition, 48 Hours Break-in-Running before implementing Performance and Sound Testing

Item	Rated Condition	Max. Load Condition
E.T.(°C)/C.T.(°C)/S.H.(K)/ S.C.(K)/A.T.(°C)	-6.7/48.9/11.1/0/35	10/65/11.9/0/46.1
Cooling Capacity Deviation	≥92.5%	/
Power Deviation	≤107.5%	/
COP Deviation	≥92.5%	/

3. Internal Protector

Protection Method	Config	Parameter		
External Overload Protector	With	Vendor	Vendor1	Vendor2
		Model	UP9NY0506-XX	
		Open Temp.(°C)	135±5	150±5
		Close Temp. (°C)	60±9	208-240
		Short Time Trip	174A 3-10s	A s
Internal Pressure Relieve Valve	With	2.76-3.10MPa		

4. Accessory

Item	Name	P.N.	PCS
1	Grommet	070-0003-00	4
2	Sleeve	010-0014-00	4

5. Compressor Operating Envelope

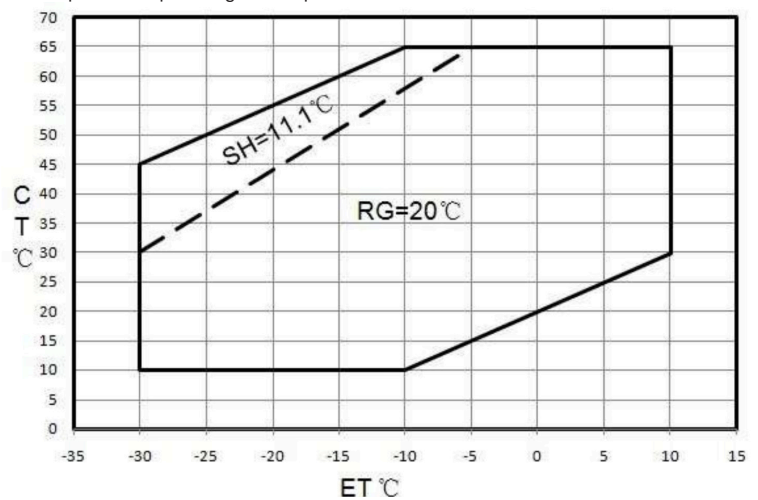

Compressor Performance Sheet

- » Performance Based on Superheat is within the Operating Envelope, Subcooling after Condenser is 0K;
- » Performance Calculated by Coefficients of Polynomial is Only Suitable for the Condition within Operating Envelope
- » Capacity, Power can be Calculated by Coefficients of Polynomial

Performance Table										
Item	E.T. °C	-30	-25	-20	-15	-10	-5	0	5	10
Cooling Cap.(W)	65					17307	20925	25218	30200	35881
	60				15620	18969	23019	27781	33269	39494
	55			13870	16857	20569	25018	30219	36181	42918
	50		12256	14786	18066	22110	26929	32535	38941	46158
	45	10975	12955	15711	19255	23599	28755	34736	41553	49220
	40	11564	13701	16651	20427	25039	30502	36826	44024	52109
	35	12236	14498	17612	21587	26437	32174	38811	46358	54829
	30	12995	15352	18597	22741	27798	33778	40695	48560	57386
	25	13847	16267	19612	23894	29125	35318	42484	50636	
	20	14797	17249	20663	25051	30425	36798	44182		
10	17012	19433	22890	27396	32963					
Power(W)	65					14307	15069	15753	16411	17096
	60				12486	13256	13912	14507	15093	15724
	55			10785	11597	12261	12827	13350	13881	14475
	50		9153	10042	10748	11321	11815	12283	12777	13349
	45	7538	8541	9323	9939	10440	10878	11308	11781	12350
	40	7042	7937	8630	9172	9617	10018	10426	10896	11478
	35	6539	7344	7963	8449	8856	9235	9639	10122	10736
	30	6030	6761	7324	7771	8156	8531	8949	9462	10123
	25	5516	6191	6715	7140	7521	7909	8356	8917	
	20	5000	5635	6137	6558	6951	7368	7863		
10	3965	4572	5081	5543	6012					

Ten Coefficients of Polynomial			
Expression	$z = p_0 + p_1*x + p_2*y + p_3*x^2 + p_4*x*y + p_5*y^2 + p_6*x^3 + p_7*x^2*y + p_8*x*y^2 + p_9*y^3$		
Description	z: Cooling Capacity(W) or Power (W) Specially: Heating Capacity(W)=Cooling Capacity(W)+Power (W) x: E.T. °C y: C.T. °C p0~p9: Coefficients of Polynomial		
Cooling Cap. Factor	Value	Power Factor	Value
p0	50175.524959	p0	6914.027204
p1	1705.111548	p1	188.933387
p2	-270.987236	p2	5.484987
p3	23.440588	p3	3.985445
p4	-3.811855	p4	-5.298204
p5	-1.298188	p5	2.138591
p6	0.016281	p6	0.070237
p7	-0.148987	p7	-0.069259
p8	-0.125498	p8	0.068145
p9	-0.006766	p9	-0.002013

Notes: Coefficients of polynomial are based on the fitting results of some sample data, which can be used as a reference of compressor selection, but cannot completely eliminate customer's test.

Grommet Drawing

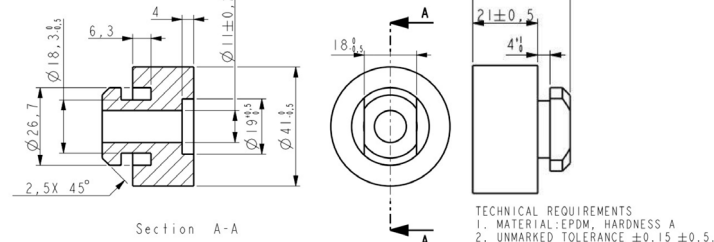

Sleeve Drawing

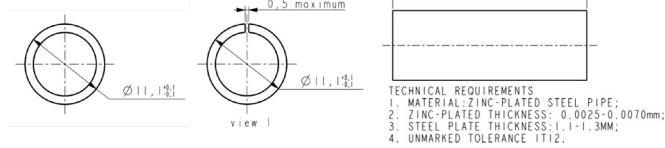

T-Box Layout Standard



Notes

- » It is not allowed to perform vacuum in the system by using the refrigeration compressor. The compressor can start only after the refrigerant charged. In some cases, such as on the field site, if it is limited by the situation that can't charge the required volume of refrigerant, 50% of the required refrigerant is charged necessary before the compressor starts. Double check the system and make sure everything is under safe status, then power on the compressor and charge the remained refrigerant when the compressor is running.
- » It is not allowed to charge the refrigerant from the suction or discharge line closes to the compressor. The charge port should be arranged on the connection pipe of suction line accumulator or receiver, which is on the side far away to the compressor, to avoid the liquid refrigerant flood back.
- » Refrigerant charge limitation: the ratio between the weight of oil and refrigerant should be >=0.4.
- » It is not allowed to vacuum by compressor, not allowed to run the compressor without refrigerant, and not allowed to run the compressor on the reversed direction for long duration.
- » The compressor can only work with approved refrigerant.
- » The compressor is not allowed to work outside its envelope, the system should guarantee the suction line superheat and avoid the liquid refrigerant flood back.
- » When the suction and discharge plugs are removed, the assembly and brazing should be done in 15 minutes.
- » The frequently start/stop should be avoided. The suggested minimum continuous running time is 10 minutes to guarantee the safe oil level (>=50% initial charge volume), the suggested minimum interval duration between start and stop is 3 minutes.
- » The deviation of supplied voltage should be less than +/-10% of rated voltage.
- » A 90W crankcase heater is recommended to avoid the refrigerant migration during the off circle and flood start. The crankcase heater should be power on 12 hours earlier than the first start or restart after long duration off.
- » The system should be equipped with necessary protection devices, such as pressure, temperature, oil return, overcurrent and phase fault, etc.
- » The compressor is not allowed to lay down or place upside down during transportation, stock and installation. The maximum inclination is 15° when the compressor is running.

Drawings

Outline Drawing

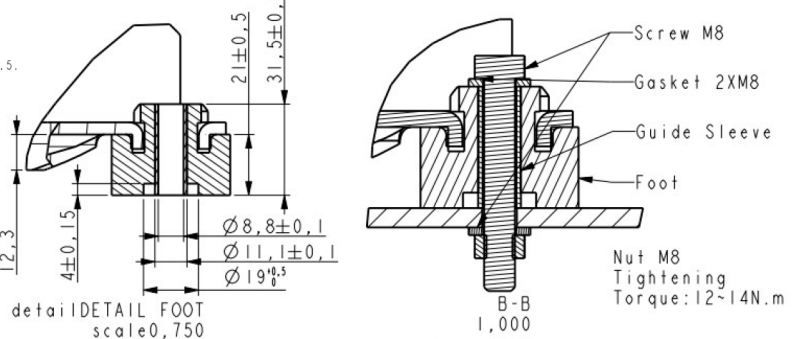
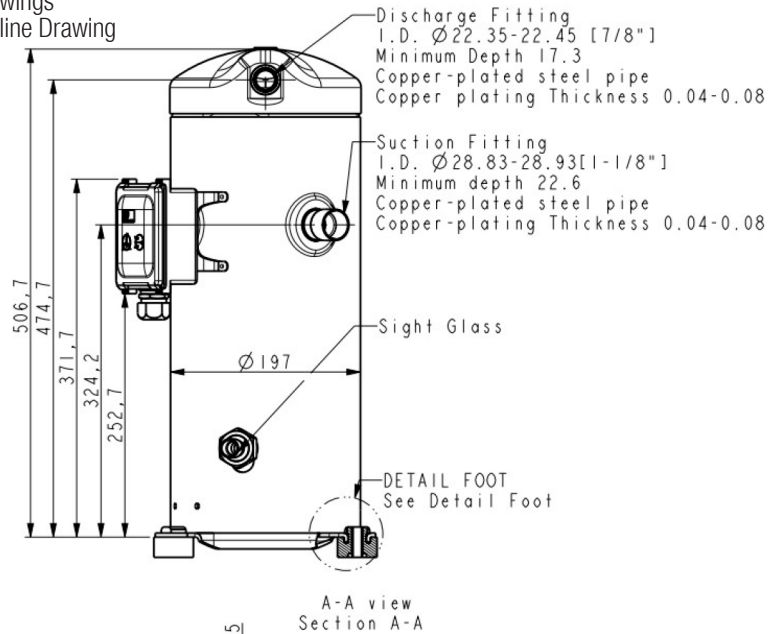

TECHNICAL REQUIREMENTS
1. ALL TOLERANCES UNLESS OTHERWISE SPECIFIED: ±2
2. TUBE ENDS MUST BE PLUGGED

Application

- » See Details in the YM serial MBP refrigerant scroll compressor application manual

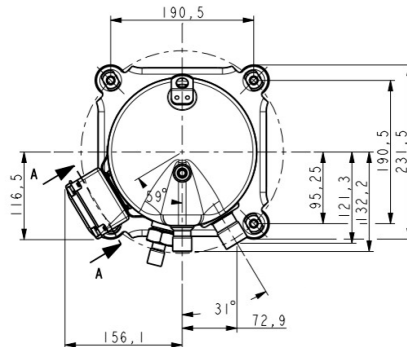

- » Single Phase Compressor Wiring Diagram
Only for single phase