

Basic Specification	
Model	YM34E7G-100 (Including Extended Model)
Type	Low Side Shell Design Scroll Compressor
Application	Medium Temp. Refrigeration
Power	2 HP
Capacity (BTU/Hr)	14819
Refrigerant	R-404A
Displacement(cc/rev)	33.3
Cooling Capacity(W) <sup>(a)</sup>	4420
Input Power(W) <sup>(a)</sup>	2381
RLA(A) <sup>(a)</sup>	9.1
Cooling COP(W/W) <sup>(a)</sup>	1.86
Power Supply	208-230V/3~/60Hz
Min. Operating Voltage(V)	187
Max. Operating Voltage(V)	253
LRA(A)	88
Max. Operating Current(A) <sup>(b)</sup>	10.8
Rated Speed(r/min) <sup>(a)</sup>	3500
Compressor Weight (With Oil)(kg)	30
Oil Type	POE
Oil Kinematic Viscosity(cSt, 40°C)	32
Oil Density(kg/L, 20°C)	0.977
Primary Charge(L)	1.4
Recharge(L)	1.25
Oil Circulation Rate <sup>(a)</sup>	≤1%
Rated Sound(Sound Power)(dBA) <sup>(c)</sup>	73
Max. Operating Sound in Running Envelope (Sound Power)(dBA)	78
Vibration Displacement Peak-Peak(mm) <sup>(d)</sup>	≤0.09
Moisture(mg)	≤500
Impurity(mg)	≤80
LVS(V) <sup>(e)</sup>	177
MOV (V) <sup>(f)</sup>	187
Start Capacitor(μF/V)	/
Start Relay	/
Run Capacitor(μF/V)	/
IP Class of Terminal Box	IP21
Compressor Color	Black

Motor Parameters	
Motor Type	Three-phase asynchronous motor
Motor Pole	2
Motor Insulation Class(°C)	130(B Class)
Line to Line Resistance UV(CS)(Ω, 25°C)	1.003(±10%)
Line to Line Resistance UW(CR)(Ω, 25°C)	1.003(±10%)
Line to Line Resistance VW(SR)(Ω, 25°C)	1.003(±10%)
Dielectric Strength	2000VAC / 1s / 60Hz or 60Hz, Leakage Current≤5mA
Insulation Resistance(MΩ)	≥20
Ground Resistance(Ω)	≤0.1

Safety Operating Limit	
Tightness Test Pressure (MPa)	3.8-4.0
Max. Operating Pressure	
High Side(MPa)	H3.2/L2.0
Low Side(MPa)	
Compressor FreeSpace(Without Oil)	
High Side(L)	H1.0/L3.8
Low Side(L)	
Max. Refrigerant Charge(kg)	See Notes
Discharge Temperature Limit(°C)	≤125 (120mm to compressor discharge connection and well insulated)
Start-Stop Interval	See Notes

Performance Condition:

Condition	Condition Description
a	Rated Condition
b	Max. Load Condition, 90% Rated Voltage
c	Rated Condition, A Weighted Sound Power
d	Rated Condition, Max Operating Normal Displacement of Compressor Housing
e	Discharge Pressure and Suction Pressure: Saturated Refrigerant Pressure at 40°C
f	Max. Load Condition

2. Rated Condition, 48 Hours Break-in-Running before implementing Performance and Sound Testing

Item	Rated Condition	Max. Load Condition
E.T.(°C)/C.T.(°C)/S.H.(K)/S.C.(K)/A.T.(°C)	-6.7/48.9/11.1/0/35	10/65/11.9/0/46.1
Cooling Capacity Deviation	≥92.5%	-
Power Deviation	≤107.5%	-
COP Deviation	≥92.5%	-

3. Internal Protector

Protection Method	Config	Parameter		
Internal Overload Protector	With	Vendor	Vendor 1	Vendor 2
		Model	37HM408-XX	
		Open Temp.(°C)	125±5	
		Close Temp. (°C)	60±9	
		Short Time Trip	64A 2-10s	A S
Internal Pressure Relieve Valve	With	2.76-3.10MPa		

4. Accessory

Item	Name	P.N.	PCS
1	Grommet	070-0003-00	4
2	Sleeve	010-0014-00	4

5. Compressor Operating Envelope

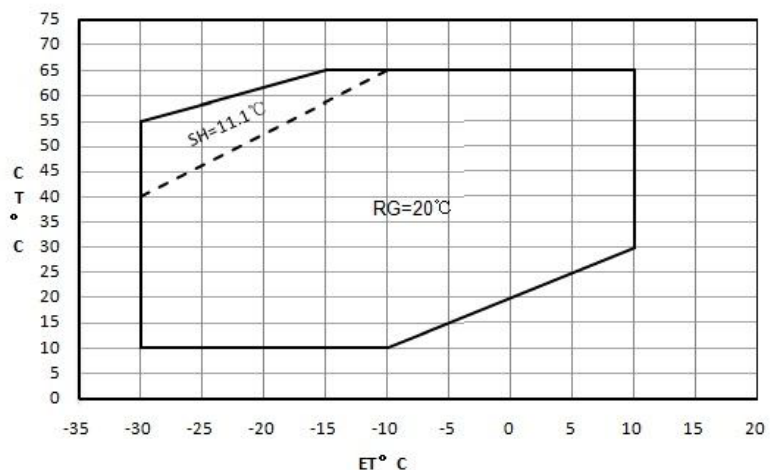

EVI control logic(only for EVI module)

- » Recommend system subcooling 5K
- » DLT≤95°C,control superheat of injection line=5K
- » DLT>95°C,control DLT=95°C
- » Max injection pressure≤2.0MPa

Compressor Performance Sheet

- » Performance Based on Superheat is within the Operating Envelope, Subcooling after Condenser is OK;
- » Performance Calculated by Coefficients of Polynomial is Only Suitable for the Condition within Operating Envelope
- » Capacity, Power can be Calculated by Coefficients of Polynomial

Performance Table										
Item	E.T.(°C) C.T.(°C)	Temperature (°C)								
		-30	-25	-20	-15	-10	-5	0	5	10
Cooling Cap.(W)	65				2256	2735	3278	3905	4635	5486
	60			2175	2659	3201	3822	4540	5373	6341
	55	1556	2002	2482	3017	3624	4322	5130	6067	7152
	50	1764	2235	2753	3338	4009	4785	5684	6725	7926
	45	1945	2439	2995	3631	4366	5219	6209	7353	8672
	40	2104	2623	3217	3904	4703	5633	6713	7961	9397
	35	2250	2794	3425	4163	5026	6033	7203	8556	10108
	30	2391	2959	3628	4416	5343	6428	7689	9145	10814
	25	2689	3127	3833	4672	5663	6825	8176	9736	
	20	2689	3305	4048	4938	5993	7233	8674		
10	3058	3722	4541	5532	6715					
Power(W)	65			2945	3076	3197	3307	3407	3495	
	60			2570	2697	2817	2929	3032	3125	3208
	55	2106	2231	2352	2468	2579	2683	2779	2868	2947
	50	1931	2043	2153	2259	2361	2458	2549	2633	2709
	45	1770	1871	1970	2068	2162	2253	2339	2420	2494
	40	1625	1714	1804	1894	1982	2067	2150	2228	2301
	35	1492	1572	1654	1736	1818	1900	1979	2056	2129
	30	1372	1443	1517	1593	1671	1749	1826	1902	1976
	25	1263	1326	1393	1464	1538	1614	1690	1767	
	20	1164	1220	1281	1348	1419	1493	1570		
10	992	1036	1090	1151	1219					

Ten Coefficients of Polynomial			
Expression	$z = p_0 + p_1*x + p_2*y + p_3*x^2 + p_4*x*y + p_5*y^2 + p_6*x^3 + p_7*x^2*y + p_8*x*y^2 + p_9*y^3$		
Description	z: Cooling Capacity(W) or Power (W) Specially: Heating Capacity(W)=Cooling Capacity(W)+Power (W) x: E.T. °C y: C.T. °C p0~p9: Coefficients of Polynomial		
Cooling Cap. Factor	Value	Power Factor	Value
p0	10921.74413	p0	1272.872578
p1	387.4571019	p1	18.496148
p2	-127.8066881	p2	13.053923
p3	5.489122943	p3	0.144999
p4	-3.877359396	p4	-0.198909
p5	0.978655698	p5	0.217034
p6	0.025071849	p6	-0.00123
p7	-0.052934038	p7	-0.00578
p8	-9.61509E-05	p8	0.003868
p9	-0.010354868	p9	0.001461

Notes: Coefficients of polynomial are based on the fitting results of some sample data, which can be used as a reference of compressor selection, but cannot completely eliminate customer's test.

Grommet Drawing 070-0003-00

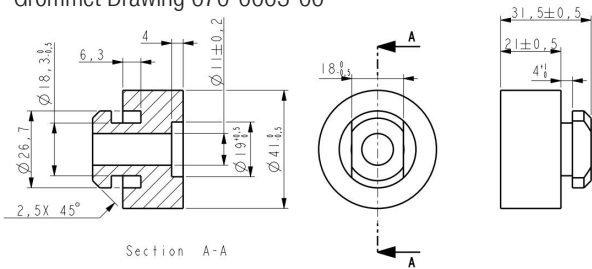

Sleeve Drawing 010-0014-00

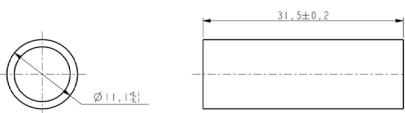

T-Box Layout Standard

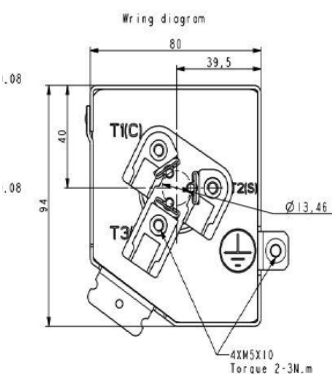

Notes

- » It is not allowed to perform vacuum in the system by using the refrigeration compressor. The compressor can start only after the refrigerant charged. In some cases, such as on the field site, if it is limited by the situation that can't charge the required volume of refrigerant, 50% of the required refrigerant is charged necessary before the compressor starts. Double check the system and make sure everything is under safe status, then power on the compressor and charge the remained refrigerant when the compressor is running.
- » It is not allowed to charge the refrigerant from the suction or discharge line closes to the compressor. The charge port should be arranged on the connection pipe of suction line accumulator or receiver, which is on the side far away to the compressor, to avoid the liquid refrigerant flood back.
- » Refrigerant charge limitation: the ratio between the weight of oil and refrigerant should be  $\geq 0.4$ .
- » It is not allowed to vacuum by compressor, not allowed to run the compressor without refrigerant, and not allowed to run the compressor on the reversed direction for long duration.
- » The compressor can only work with approved refrigerant.
- » The compressor is not allowed to work outside its envelope, the system should guarantee the suction line superheat and avoid the liquid refrigerant flood back.
- » When the suction and discharge plugs are removed, the assembly and brazing should be done in 15 minutes.
- » The frequently start/stop should be avoided. The suggested minimum continuous running time is 10 minutes to guarantee the safe oil level ( $\geq 50\%$  initial charge volume), the suggested minimum interval duration between start and stop is 3 minutes.
- » The deviation of supplied voltage should be less than  $\pm 10\%$  of rated voltage.
- » A 70W crankcase heater is recommended to avoid the refrigerant migration during the off circle and flood start. The crankcase heater should be power on 12 hours earlier than the first start or restart after long duration off.
- » The system should be equipped with necessary protection devices, such as pressure, temperature, oil return, overcurrent and phase fault, etc.
- » The compressor is not allowed to lay down or place upside down during transportation, stock and installation. The maximum inclination is  $15^\circ$  when the compressor is running.

Drawings  
Outline Drawing

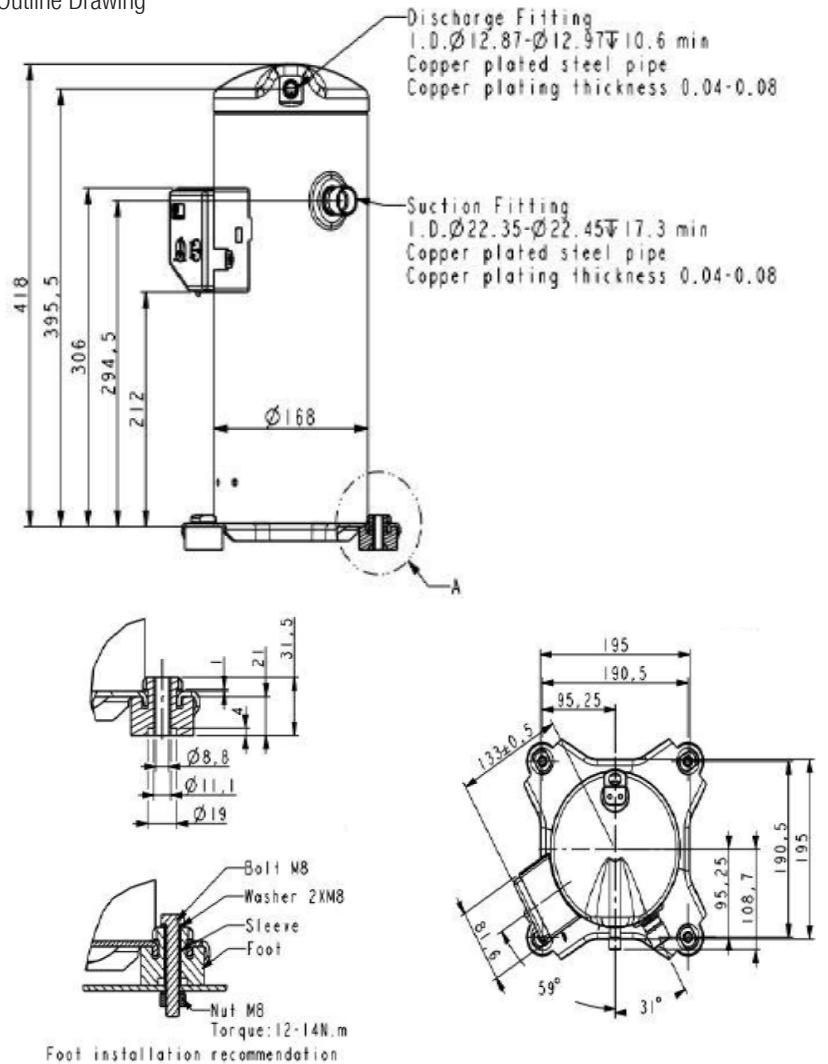

Application

- » See Details in the YM serial MBP refrigerant scroll compressor application manual