

Basic Specification	
Model	YM350E1S-100
Type	Low Side Shell Design Scroll Compressor
Application	Medium temperature refrigeration
Power	22 HP
Capacity (BTU/Hr)	135625
Refrigerant	R404A
Displacement(cc/rev)	332.8
Cooling Capacity(W) <sup>(a)</sup>	39960
Input Power(W) <sup>(a)</sup>	19980
RLA(A) <sup>(a)</sup>	29.4
Cooling COP(W/W) <sup>(a)</sup>	2.0
Power Supply	380-420V/3~/50Hz or 460V/3~/60Hz
Min. Operating Voltage(V)	414
Max. Operating Voltage(V)	506
LRA(A)	205
Max. Operating Current(A) <sup>(b)</sup>	41
Rated Speed(r/min) <sup>(a)</sup>	3500
Compressor Weight (With Oil)(kg)	100
Oil Type	POE
Oil Kinematic Viscosity(cSt, 40°C)	32
Oil Density(kg/L, 20°C)	0.977
Primary Charge(L)	5.5
Recharge(L)	5.3
Oil Circulation Rate <sup>(a)</sup>	≤1%
Rated Sound(Sound Power)(dBA) <sup>(c)</sup>	82
Max. Operating Sound in Running Envelope (Sound Power)(dBA)	89
Vibration Displacement Peak-Peak(mm) <sup>(d)</sup>	≤0.12
Moisture(mg)	≤4000
Impurity(mg)	≤380
LVS(V) <sup>(e)</sup>	391
MOV (V) <sup>(f)</sup>	414
Start Capacitor(μF/V)	/
Start Relay	/
Run Capacitor(μF/V)	/
IP Class of Terminal Box	IP54
Compressor Color	Black

Motor Parameters	
Motor Type	Three-phase asynchronous motor
Motor Pole	2
Motor Insulation Class(°C)	130 (B Class)
Line to Line Resistance UV(CS)(Ω, 25°C)	0.46 ( ± 10%)
Line to Line Resistance UW(CR)(Ω, 25°C)	0.46 ( ± 10%)
Line to Line Resistance VW(SR)(Ω, 25°C)	0.46 ( ± 10%)
Dielectric Strength	2000VAC / 1s / 50Hz or 60Hz, Leakage Current≤5mA
Insulation Resistance(MΩ)	≥20
Ground Resistance(Ω)	≤0.1

Safety Operating Limit	
Tightness Test Pressure (MPa)	3.8-4.0
Max. Operating Pressure	
High Side(MPa)	H3.2/L2.0
Low Side(MPa)	
Compressor FreeSpace (Without Oil)	
High Side(L)	H1.75/L14.4
Low Side(L)	
Max. Refrigerant Charge(kg)	See Notes
Discharge Temperature Limit(°C)	≤125 (120mm to compressor discharge connection and well insulated)
Start-Stop Interval	See Notes

Performance Condition:

Condition	Condition Description
a	Rated Condition
b	Max. Load Condition, 90% Rated Voltage
c	Rated Condition, A Weighted Sound Power
d	Rated Condition, Max Operating Normal Displacement of Compressor Housing
e	Discharge Pressure and Suction Pressure: Saturated Refrigerant Pressure at 40°C
f	Max. Load Condition

2. Rated Condition, 48 Hours Break-in-Running before implementing Performance and Sound Testing

Item	Rated Condition	Max. Load Condition
E.T.(°C)/C.T.(°C)/S.H.(K)/S.C.(K)/A.T.(°C)	-6.7/48.9/11.1/0/35	10/65/11.9/8.3/46.1
Cooling Capacity Deviation	≥95.0%	/
Power Deviation	≤105.0%	/
COP Deviation	≥95.0%	/

3. Internal Protector

Protection Method	Config	Parameter		
External Overload Protector	With	Model	INT69-E1	SE-E1
		Open Temp.(°C)	150±5	150±5
		Supply Voltage(V)	115-230	208-240
		Reset Method	Restart after power off	Restart after power off
Internal Pressure Relieve Valve	With	2.76-3.10MPa		

4. Accessory

Item	Name	P.N.	PCS
1	Grommet	070-3033-00	4
2	Sleeve	010-3033-00	4
3	Grommet Screw Grommet Nut	GB/T5783-2000	4
		GB/T6170-2000	4
4	Grommet Washer	GB/T96.1 10	8

5. Compressor Operating Envelope

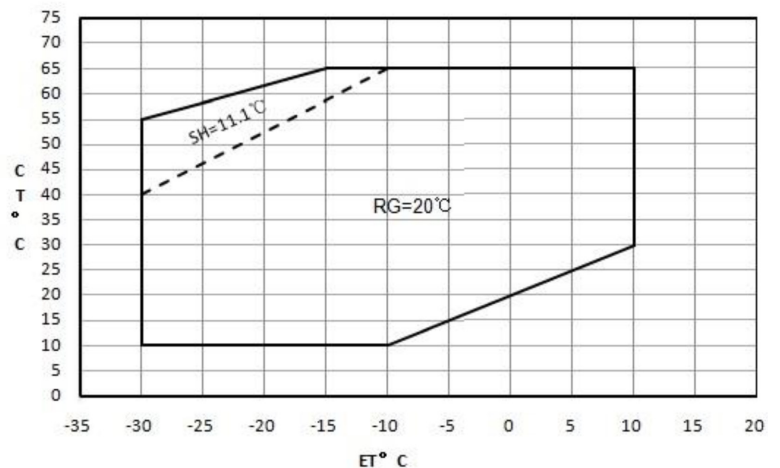

Compressor Performance Sheet

- » Performance Based on Superheat is within the Operating Envelope, Subcooling after Condenser is OK;
- » Performance Calculated by Coefficients of Polynomial is Only Suitable for the Condition within Operating Envelope
- » Capacity, Power can be Calculated by Coefficients of Polynomial

Performance Table										
Item	E.T.(°C) C.T.(°C)	-30	-25	-20	-15	-10	-5	0	5	10
		Cooling Cap(W)	65				17488	22446	30660	35750
60				18302	20918	29785	34934	41353	49126	58334
55	11855		16020	20184	27940	33073	39387	46965	55889	66242
50	13430		17748	25381	30422	36556	43864	52430	62335	73662
45	15005		22361	27236	33115	40079	48211	57594	68308	80437
40	19137		23771	29319	35864	43488	52273	62301	73654	86415
35	20280		25424	31475	38516	46628	55895	66397	78218	91440
30	21684		27166	33549	40914	49344	58922	69728	81845	95356
25	23192		28842	35386	42905	51482	61198	72137	84380	
20	24651		30298	36831	44332	52885	62570	73471		
Power (W)	15	25905	31377	37729	45043	53400	62883			
	10	26800	31927	37926	44880	52871				
	65				23989	25280	26665	27934	29034	29940
	60			21078	22378	23471	24754	25899	26879	27668
	55	17546	18619	19693	20555	21817	22971	23991	24850	25521
	50	16480	17394	17940	19146	20275	21299	22193	22929	23480
	45	15414	15650	16765	17833	18827	19721	20487	21098	21528
	40	13708	14697	15669	16598	17457	18218	18854	19340	19647
	35	12965	13807	14635	15424	16145	16772	17278	17636	17819
	30	12269	12962	13645	14291	14873	15365	15739	15968	16026
25	11601	12144	12680	13183	13625	13979	14220	14319		
20	10944	11335	11723	12081	12381	12597	12703			
15	10280	10518	10756	10967	11124	11201				
10	9590	9673	9760	9823	9836					

RG=20°C [ ] , SH=11.1K [ ]

**Drawings**  
Outline Drawing

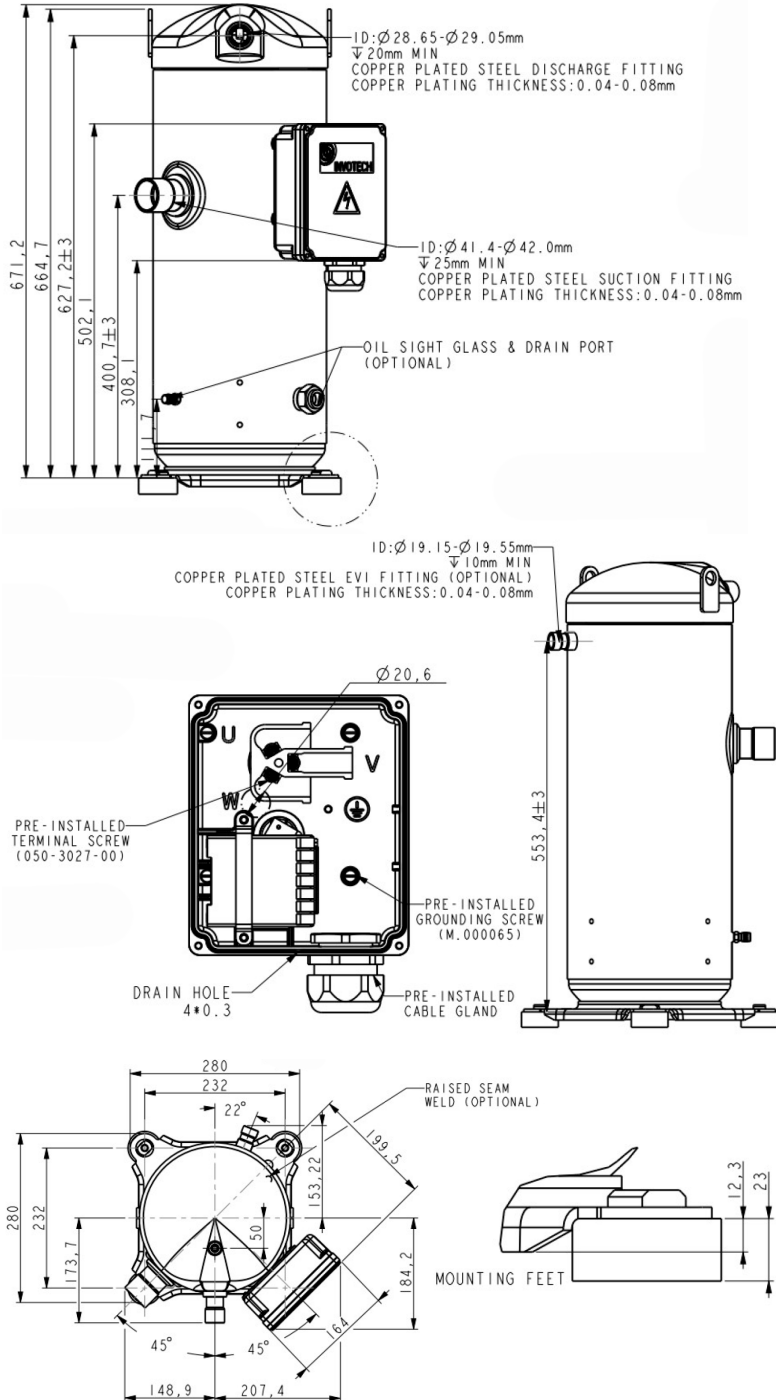

**Application**  
» See Details in the YM serial MBP refrigerant scroll compressor application manual

**Notes**

- » It is not allowed to perform vacuum in the system by using the refrigeration compressor. The compressor can start only after the refrigerant charged. In some cases, such as on the field site, if it is limited by the situation that can't charge the required volume of refrigerant, 50% of the required refrigerant is charged necessary before the compressor starts. Double check the system and make sure everything is under safe status, then power on the compressor and charge the remained refrigerant when the compressor is running.
- » It is not allowed to charge the refrigerant from the suction or discharge line closes to the compressor. The charge port should be arranged on the connection pipe of suction line accumulator or receiver, which is on the side far away to the compressor, to avoid the liquid refrigerant flood back.
- » Refrigerant charge limitation: the ratio between the weight of oil and refrigerant should be  $\geq 0.4$ .
- » It is not allowed to vacuum by compressor, not allowed to run the compressor without refrigerant, and not allowed to run the compressor on the reversed direction for long duration.
- » The compressor can only work with approved refrigerant.
- » The compressor is not allowed to work outside its envelope, the system should guarantee the suction line superheat and avoid the liquid refrigerant flood back.
- » When the suction and discharge plugs are removed, the assembly and brazing should be done in 15 minutes.
- » The frequently start/stop should be avoided. The suggested minimum continuous running time is 10 minutes to guarantee the safe oil level ( $\geq 50\%$  initial charge volume), the suggested minimum interval duration between start and stop is 3 minutes.
- » Before startup, Discharge pressure-Suction pressure  $\leq 0.3$ Mpa.
- » The deviation of supplied voltage should be less than  $\pm 10\%$  of rated voltage.
- » A 120W crankcase heater is recommended to avoid the refrigerant migration during the off circle and flood start. The crankcase heater should be power on 12 hours earlier than the first start or restart after long duration off.
- » The system should be equipped with necessary protection devices, such as pressure, temperature, oil return, overcurrent and phase fault, etc.
- » The compressor is not allowed to lay down or place upside down during transportation, stock and installation. The maximum inclination is  $15^\circ$  when the compressor is running.

**Sleeve Drawing**

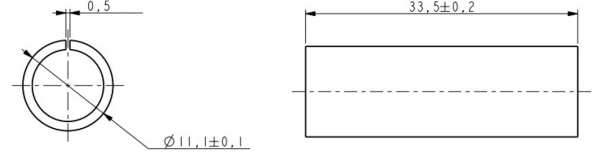

**Grommet Drawing**

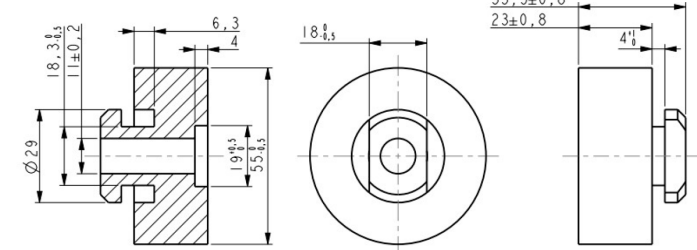

**Diagram of wiring**

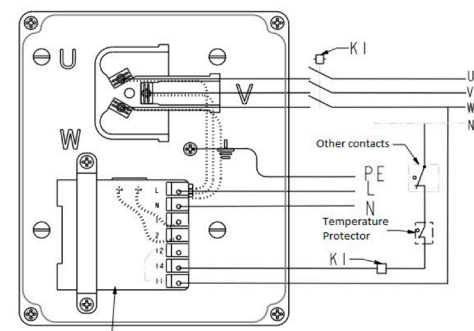

Motor protector  
Notes: The dotted line in the figure is the wire that has been connected before leaving the factory, and the solid line is the wire that needs to be connected by the customer

**How to install**

