

Basic Specification

Model	YM43E7S-100 (Including Extended Model)
Type	Low Side Shell Design Scroll Compressor
Application	Medium Temp. Refrigeration
Refrigerant	R404A
Power	2.5 HP
Capacity (BTU/Hr)	17691
Displacement(cc/rev)	42
Cooling Capacity(W) ^(a)	5270
Input Power(W) ^(a)	2800
RLA(A) ^(a)	10
Cooling COP(W/W) ^(a)	1.88
Power Supply	208-230V/3~/60Hz
Min. Operating Voltage(V)	187
Max. Operating Voltage(V)	253
LRA(A)	88
Max. Operating Current(A) ^(b)	13.3
Rated Speed(r/min) ^(a)	3500
Compressor Weight (With Oil)(kg)	30
Oil Type	POE
Oil Kinematic Viscosity(cSt, 40°C)	32
Oil Density(kg/L, 20°C)	0.977
Primary Charge(L)	1.4
Recharge(L)	1.25
Oil Circulation Rate ^(a)	≤1%
Rated Sound(Sound Power)(dBA) ^(c)	73
Max. Operating Sound in Running Envelope (Sound Power)(dBA)	78
Vibration Displacement Peak-Peak(mm) ^(d)	≤0.09
Moisture(mg)	≤500
Impurity(mg)	≤100
LVS(V) ^(e)	177
MOV (V) ^(f)	187
Start Capacitor(μF/V)	/
Start Relay	/
Run Capacitor(μF/V)	/
IP Class of Terminal Box	IP21
Compressor Color	Black

Motor Parameters

Motor Type	Three-phase asynchronous motor
Motor Pole	2
Motor Insulation Class(°C)	130(B Class)
Line to Line Resistance UV(CS)(Ω, 25°C)	1.003(± 10%)
Line to Line Resistance UW(CR)(Ω, 25°C)	1.003(± 10%)
Line to Line Resistance VW(SR)(Ω, 25°C)	1.003(± 10%)
Dielectric Strength	2000VAC / 1s / 60Hz, Leakage Current≤5mA
Insulation Resistance(MΩ)	≥20
Ground Resistance(Ω)	≤0.1

Safety Operating Limit

Tightness Test Pressure (MPa)	3.8-4.0
Max. Operating Pressure	
High Side(MPa) Low Side(MPa)	H3.2/L2.0
Compressor FreeSpace(Without Oil)	
High Side(L) Low Side(L)	H1.0/L3.6
Max. Refrigerant Charge(kg)	See Notes
Discharge Temperature Limit(°C)	≤125 (120mm to compressor discharge connection and well insulated)
Start-Stop Interval	See Notes

Performance Condition:

Condition	Condition Description
a	Rated Condition
b	Max. Load Condition, 90% Rated Voltage
c	Rated Condition, A Weighted Sound Power
d	Rated Condition, Max Operating Normal Displacement of Compressor Housing
e	Discharge Pressure and Suction Pressure: Saturated Refrigerant Pressure at 40°C
f	Max. Load Condition

2. Rated Condition, 48 Hours Break-in-Running before implementing Performance and Sound Testing

Item	Rated Condition	Max. Load Condition
E.T.(°C)/C.T.(°C)/S.H.(K)/ S.C.(K)/ A.T.(°C)	-6.7/48.9/11.1/0/35	10/65/11.9/0/46.1
Cooling Capacity Deviation	≥92.5%	-
Power Deviation	≤107.5%	-
COP Deviation	≥92.5%	-

3. Internal Protector

Protection Method	Config	Parameter		
Internal Overload Protector	With	Vendor	Vendor 1	Vendor 2
		Model	37HM408-XX	
		Open Temp.(°C)	125±5	
		Close Temp. (°C)	60±9	
		Short Time Trip	64A 2-10s	A S
Internal Pressure Relieve Valve	With	2.76-3.10MPa		

4. Accessory

Item	Name	P.N.	PCS
1	Grommet	070-0003-00	4
2	Sleeve	010-0014-00	4

5. Compressor Operating Envelope

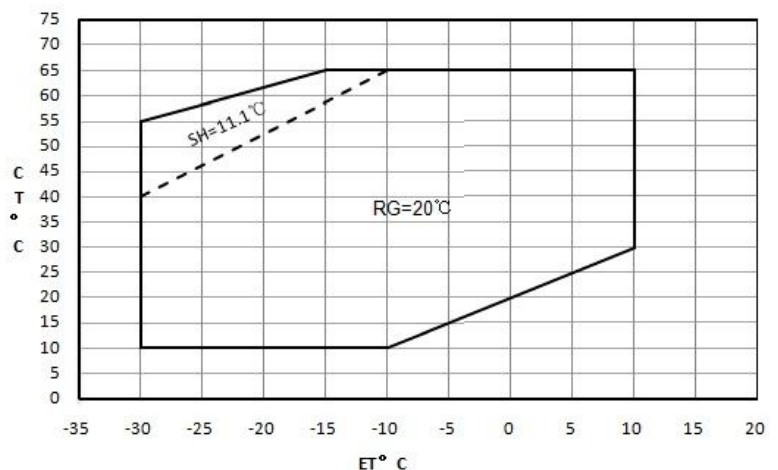

EVI control logic(only for EVI module)

- » Recommend system subcooling 5K
- » DLT≤95°C,control superheat of injection line=5K
- » DLT>95°C,control DLT=95°C
- » Max injection pressure≤2.0MPa

Compressor Performance Sheet

- » Performance Based on Superheat is within the Operating Envelope, Subcooling after Condenser is OK;
- » Performance Calculated by Coefficients of Polynomial is Only Suitable for the Condition within Operating Envelope
- » Capacity, Power can be Calculated by Coefficients of Polynomial

Performance Table											
Item	ET(°C)		-30	-25	-20	-15	-10	-5	0	5	10
	CT(°C)										
Cooling Cap. (W)	65				2692	3263	3911	4659	5530	6545	
	60			2595	3172	3819	4560	5416	6410	7565	
	55	1856	2388	2962	3599	4323	5156	6120	7238	8533	
	50	2105	2666	3285	3983	4783	5709	6781	8023	9457	
	45	2320	2910	3574	4332	5209	6227	7407	8773	10346	
	40	2510	3129	3838	4657	5610	6720	8008	9498	11211	
	35	2685	3333	4086	4966	5996	7198	8594	10207	12060	
	30	2853	3530	4328	5269	6375	7669	9173	10910	12902	
	25	3024	3730	4573	5574	6757	8143	9755	11616		
	20	3208	3943	4830	5892	7150	8629	10349			
10	3648	4441	5418	6600	8012						
Power (W)	65				3457	3610	3752	3882	3999	4102	
	60			3016	3165	3306	3437	3558	3668	3765	
	55	2472	2618	2760	2897	3027	3149	3262	3366	3458	
	50	2266	2398	2526	2651	2771	2885	2992	3090	3180	
	45	2078	2196	2313	2427	2538	2645	2746	2840	2927	
	40	1907	2012	2118	223	2326	2427	2523	2615	2701	
	35	1751	1845	1940	2038	2134	2230	2323	2413	2499	
	30	1610	1693	1780	1870	1961	2052	2143	2233	2320	
	25	1482	1556	1635	1719	1805	1894	1984	2073		
	20	1366	1431	1504	1583	1666	1753	1842			
10	1164	1217	1279	1351	1431						

Notes: Coefficients of polynomial are based on the fitting results of some sample data, which can be used as a reference of compressor selection, but cannot completely eliminate customer's test.

Notes

- » It is not allowed to perform vacuum in the system by using the refrigeration compressor. The compressor can start only after the refrigerant charged. In some cases, such as on the field site, if it is limited by the situation that can't charge the required volume of refrigerant, 50% of the required refrigerant is charged necessary before the compressor starts. Double check the system and make sure everything is under safe status, then power on the compressor and charge the remained refrigerant when the compressor is running.
- » It is not allowed to charge the refrigerant from the suction or discharge line closes to the compressor. The charge port should be arranged on the connection pipe of suction line accumulator or receiver, which is on the side far away to the compressor, to avoid the liquid refrigerant flood back.
- » Refrigerant charge limitation: the ratio between the weight of oil and refrigerant should be ≥ 0.4 .
- » It is not allowed to vacuum by compressor, not allowed to run the compressor without refrigerant, and not allowed to run the compressor on the reversed direction for long duration.
- » The compressor can only work with approved refrigerant.
- » The compressor is not allowed to work outside its envelope, the system should guarantee the suction line superheat and avoid the liquid refrigerant flood back.
- » When the suction and discharge plugs are removed, the assembly and brazing should be done in 15 minutes.
- » The frequently start/stop should be avoided. The suggested minimum continuous running time is 10 minutes to guarantee the safe oil level ($\geq 50\%$ initial charge volume), the suggested minimum interval duration between start and stop is 3 minutes.
- » The deviation of supplied voltage should be less than $\pm 10\%$ of rated voltage.
- » A 70W crankcase heater is recommended to avoid the refrigerant migration during the off circle and flood start. The crankcase heater should be power on 12 hours earlier than the first start or restart after long duration off.
- » The system should be equipped with necessary protection devices, such as pressure, temperature, oil return, overcurrent and phase fault, etc.
- » The compressor is not allowed to lay down or place upside down during transportation, stock and installation. The maximum inclination is 15° when the compressor is running.

Ten Coefficients of Polynomial			
Expression	$z = p_0 + p_1x + p_2y + p_3x^2 + p_4xy + p_5y^2 + p_6x^3 + p_7x^2y + p_8xy^2 + p_9y^3$		
Description	z: Cooling Capacity(W) or Power (W) Specially: Heating Capacity(W)=Cooling Capacity(W)+Power (W) x: E.T. °C y: C.T. °C p0~p9: Coefficients of Polynomial		
Cooling Cap. Factor	Value	Power Factor	Value
p0	13030.09909	p0	1436.504435
p1	462.2525823	p1	20.873887
p2	-152.4787425	p2	14.732047
p3	6.548754415	p3	0.163639
p4	-4.625852302	p4	-0.22448
p5	1.167577585	p5	0.244934
p6	0.029911774	p6	-0.001388
p7	-0.063152528	p7	-0.006523
p8	-0.000114792	p8	0.004366
p9	-0.012353434	p9	0.001649

Drawings
Outline Drawing

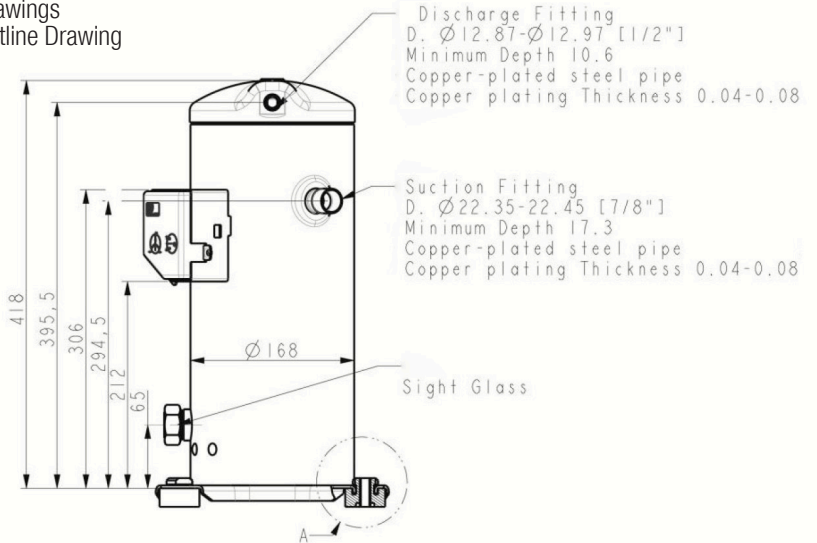

Grommet Drawing

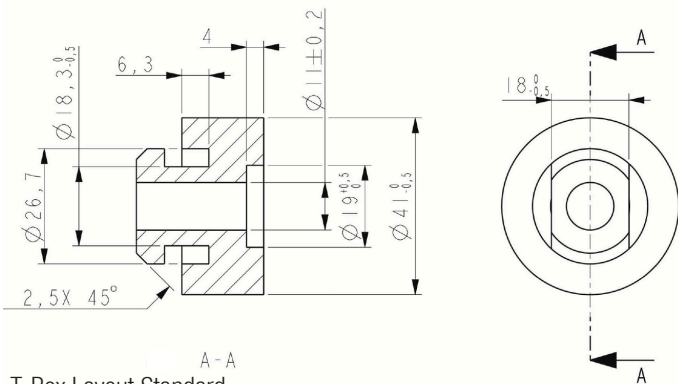

T-Box Layout Standard

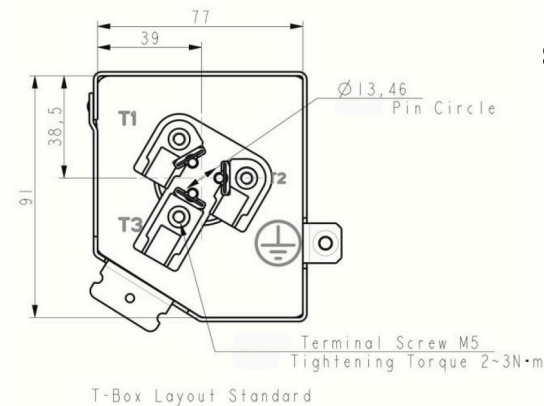

Sleeve Drawing

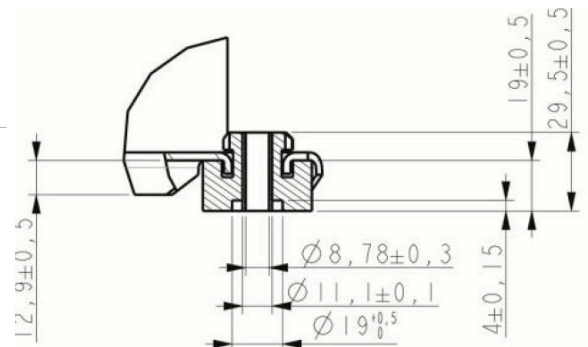
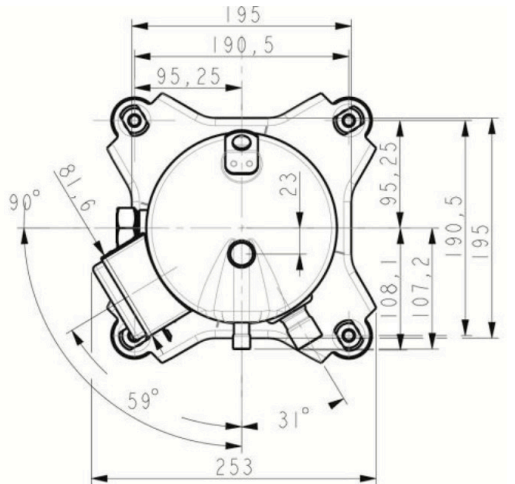
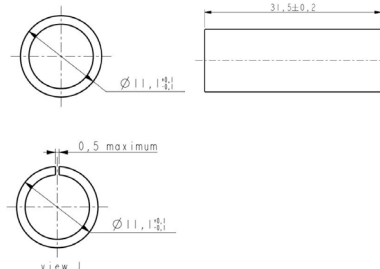

Application

- » See Details in the YM serial MBP refrigerant scroll compressor application manual