

### Basic Specification

Model	YM49E3S-100 (Including Extended Models)
Type	Low Side Shell Design Scroll Compressor
Application	Medium Temp. Refrigeration
Refrigerant	R448A/R449A
Power	3 HP
Capacity (BTU/Hr)	20560
Displacement(cc/rev)	46.6
Cooling Capacity(W) <sup>(a)</sup>	6026
Input Power(W) <sup>(a)</sup>	2744
RLA(A) <sup>(a)</sup>	12.6
Cooling COP(W/W) <sup>(a)</sup>	2.20
Power Supply	208-230V/1~/60Hz
Min. Operating Voltage(V)	187
Max. Operating Voltage(V)	253
LRA(A)	76
Max. Operating Current(A) <sup>(b)</sup>	20.9
Rated Speed(r/min) <sup>(a)</sup>	3500
Compressor Weight (With Oil)(kg)	31
Oil Type	POE
Oil Kinematic Viscosity(cSt, 40°C)	32
Oil Density(kg/L, 20°C)	0.977
Primary Charge(L)	1.4
Recharge(L)	1.25
Oil Circulation Rate <sup>(a)</sup>	≤1%
Rated Sound(Sound Power)(dBA) <sup>(c)</sup>	73
Max. Operating Sound in Running Envelope (Sound Power)(dBA)	78
Vibration Displacement Peak-Peak(mm) <sup>(d)</sup>	≤0.09
Moisture(mg)	≤500
Impurity(mg)	≤100
LVS(V) <sup>(e)</sup>	177
MOV (V) <sup>(f)</sup>	187
Start Capacitor(μF/V)	160
Start Relay	HLR3800-4AI3D
Run Capacitor(μF/V)	60/450
IP Class of Terminal Box	IP21
Compressor Color	Black

### Motor Parameters

Motor Type	Single-phase asynchronous motor
Motor Pole	2
Motor Insulation Class(°C)	130(B Class)
Line to Line Resistance UV(CS)(Ω, 25°C)	1.519( ± 10%)
Line to Line Resistance UW(CR)(Ω, 25°C)	0.67( ± 10%)
Line to Line Resistance VW(SR)(Ω, 25°C)	2.189( ± 10%)
Dielectric Strength	2000VAC / 1s / 60Hz, Leakage Current≤5mA
Insulation Resistance(MΩ)	≥20
Ground Resistance(Ω)	≤0.1

### Safety Operating Limit

Tightness Test Pressure (MPa)	3.8-4.0
Max. Operating Pressure	
High Side(MPa) Low Side(MPa)	H3.2/L2.0
Compressor FreeSpace(Without Oil)	
High Side(L) Low Side(L)	H1.0/L3.6
Max. Refrigerant Charge(kg)	See Notes
Discharge Temperature Limit(°C)	≤125 (120mm to compressor discharge connection and well insulated)
Start-Stop Interval	See Notes

### Performance Condition:

Condition	Condition Description
a	Rated Condition
b	Max. Load Condition, 90% Rated Voltage
c	Rated Condition, A Weighted Sound Power
d	Rated Condition, Max Operating Normal Displacement of Compressor Housing
e	Discharge Pressure and Suction Pressure: Saturated Refrigerant Pressure at 40°C
f	Max. Load Condition

### 2. Rated Condition, 48 Hours Break-in-Running before implementing Performance and Sound Testing

Item	Rated Condition	Max. Load Condition
E.T.(°C)/C.T.(°C)/S.H.(K)/ S.C.(K)/ A.T.(°C)	-6.7/48.9/11.1/0/35	10/65/11.9/0/46.1
Cooling Capacity Deviation	≥92.5%	-
Power Deviation	≤107.5%	-
COP Deviation	≥92.5%	-

### 3. Internal Protector

Protection Method	Config	Parameter		
Internal Overload Protector	With	Vendor	Vendor 1	Vendor 2
		Model	15HM2495-XX	
		Open Temp.(°C)	105±5	
		Close Temp. (°C)	61±9	
		Short Time Trip	65A 2-10s	A S
Internal Pressure Relieve Valve	With	-MPa		

### 4. Accessory

Item	Name	P.N.	PCS
1	Grommet	070-0003-00	4
2	Sleeve	010-0014-00	4
3	StartBox	110-0076-02	1

### 5. Compressor Operating Envelope

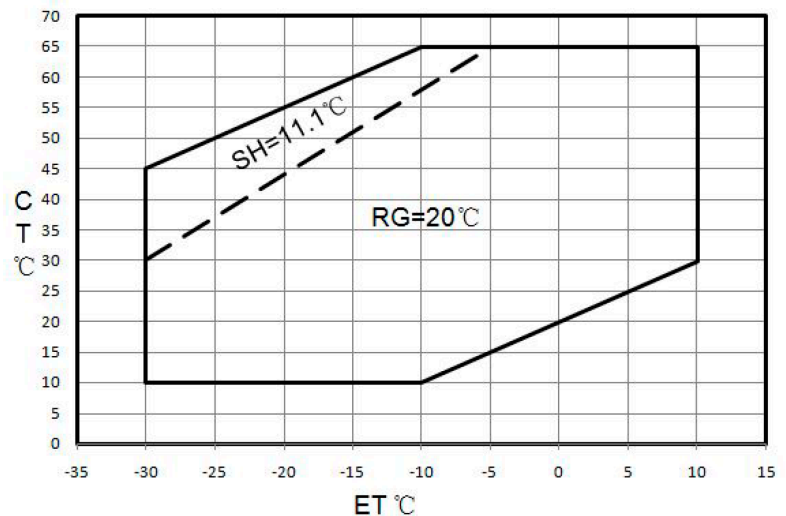

### Compressor Performance Sheet

- » Performance Based on Superheat is within the Operating Envelope, Subcooling after Condenser is OK;
- » Performance Calculated by Coefficients of Polynomial is Only Suitable for the Condition within Operating Envelope
- » Capacity, Power can be Calculated by Coefficients of Polynomial

Performance Table										
Item	E.T.P.Q									
	-30	-25	-20	-15	-10	-5	0	5	10	
Cooling Cap. (W)	C.T.(°C) 65				4251	5090	6106	7321	8757	
	60			3826	4620	5577	6719	8067	9642	
	55			3359	4106	5001	6066	7323	8793	10497
	50		2872	3569	4399	5385	6549	7910	9492	11316
	45	2387	3031	3794	4698	5765	7016	8472	10156	12088
	40	2515	3208	4027	4994	6132	7460	9001	10776	12807
	35	2662	3394	4259	5280	6477	7873	9488	11345	13464
	30	2821	3582	4483	5546	6794	8246	9926	11854	14051
	25	2984	3763	4690	5786	7073	8573	10306	12295	
	20	3142	3929	4872	5991	7307	8843	10620		
10	3412	4186	5129	6262	7607					
Power(W)	65				3509	3702	3855	3978	4076	
	60			3057	3246	3396	3516	3613	3695	
	55			2658	2843	2989	3106	3200	3280	3354
	50		2308	2487	2629	2742	2833	2910	2982	3056
	45	2002	2176	2313	2421	2508	2582	2651	2723	2805
	40	1904	2035	2138	2220	2290	2356	2425	2505	2604
	35	1792	1889	1966	2031	2093	2158	2235	2332	2457
	30	1670	1741	1801	1857	1918	1992	2086	2208	2367
	25	1540	1594	1644	1701	1770	1860	1980	2136	
	20	1406	1451	1501	1566	1652	1767	1920		
10	1141	1193	1267	1373	1518					

Notes: Coefficients of polynomial are based on the fitting results of some sample data, which can be used as a reference of compressor selection, but cannot completely eliminate customer's test.

Ten Coefficients of Polynomial			
Expression	$z = p_0 + p_1 \cdot x + p_2 \cdot y + p_3 \cdot x^2 + p_4 \cdot x \cdot y + p_5 \cdot y^2 + p_6 \cdot x^3 + p_7 \cdot x^2 \cdot y + p_8 \cdot x \cdot y^2 + p_9 \cdot y^3$		
Description	z: Cooling Capacity(W) or Power (W) Specially: Heating Capacity(W)=Cooling Capacity(W)+Power (W) x: E.T. °C y: C.T. °C p0-p9: Coefficients of Polynomial		
Cooling Cap. Factor	Value	Power Factor	Value
p0	11057.43	p0	2216.467596
p1	398.2503	p1	82.1877
p2	16.35499	p2	-38.387988
p3	5.813448	p3	1.592856
p4	-0.04912	p4	-3.038784
p5	-2.12711	p5	1.267884
p6	0.02868	p6	0.010572
p7	-0.02824	p7	-0.03414
p8	-0.04086	p8	0.033756
p9	-0.04086	p9	-0.004452

Notes

- » It is not allowed to perform vacuum in the system by using the refrigeration compressor. The compressor can start only after the refrigerant charged. In some cases, such as on the field site, if it is limited by the situation that can't charge the required volume of refrigerant, 50% of the required refrigerant is charged necessary before the compressor starts. Double check the system and make sure everything is under safe status, then power on the compressor and charge the remained refrigerant when the compressor is running.
- » It is not allowed to charge the refrigerant from the suction or discharge line closes to the compressor. The charge port should be arranged on the connection pipe of suction line accumulator or receiver, which is on the side far away to the compressor, to avoid the liquid refrigerant flood back.
- » Refrigerant charge limitation: the ratio between the weight of oil and refrigerant should be  $>=0.4$ .
- » It is not allowed to vacuum by compressor, not allowed to run the compressor without refrigerant, and not allowed to run the compressor on the reversed direction for long duration.
- » The compressor can only work with approved refrigerant.
- » The compressor is not allowed to work outside its envelope, the system should guarantee the suction line superheat and avoid the liquid refrigerant flood back.
- » When the suction and discharge plugs are removed, the assembly and brazing should be done in 15 minutes.
- » The frequently start/stop should be avoided. The suggested minimum continuous running time is 10 minutes to guarantee the safe oil level ( $>=50\%$  initial charge volume), the suggested minimum interval duration between start and stop is 3 minutes.
- » The deviation of supplied voltage should be less than  $\pm 10\%$  of rated voltage.
- » A 70W crankcase heater is recommended to avoid the refrigerant migration during the off circle and flood start. The crankcase heater should be power on 12 hours earlier than the first start or restart after long duration off.
- » The system should be equipped with necessary protection devices, such as pressure, temperature, oil return, overcurrent and phase fault, etc.
- » The compressor is not allowed to lay down or place upside down during transportation, stock and installation. The maximum inclination is  $15^\circ$  when the compressor is running.

Drawings  
Outline Drawing

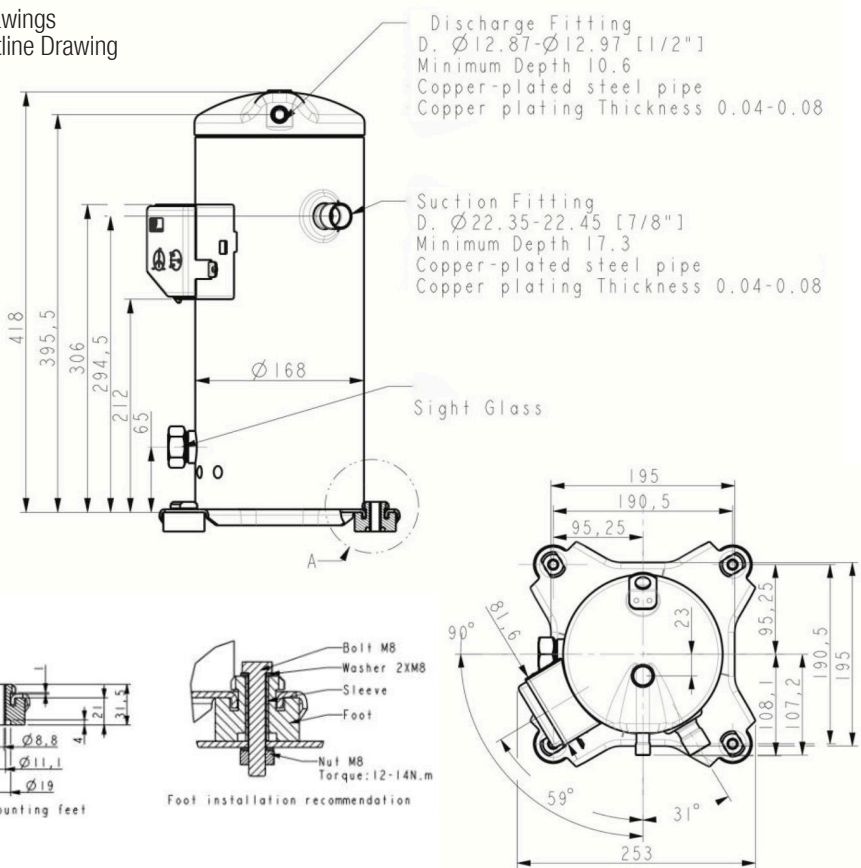

Grommet Drawing

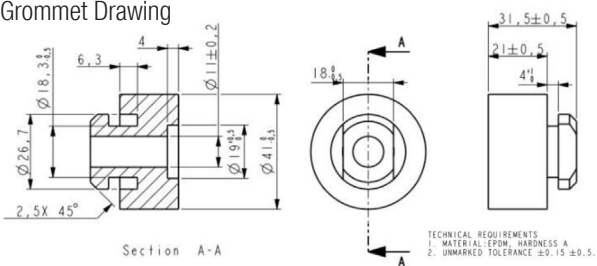

Sleeve Drawing

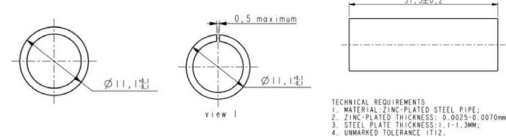

T-Box Layout Standard

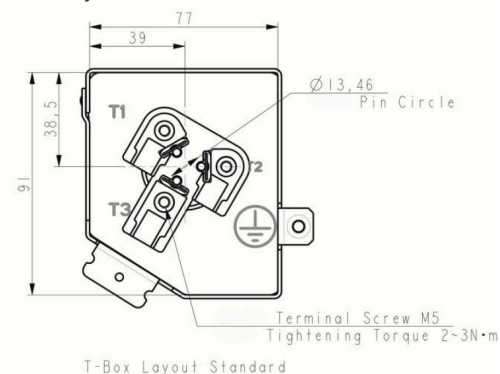

Single Phase Compressor Wiring Diagram

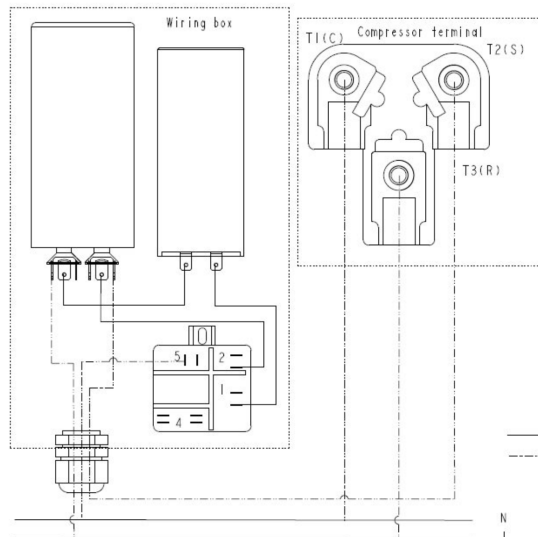

Application

- » See Details in the YM serial MBP refrigerant scroll compressor application manual