

Basic Specification	
Model	YM49E7S-100 (Including Extended Models)
Type	Low Side Shell Design Scroll Compressor
Application	Medium Temp. Refrigeration
Refrigerant	R448A / R449A
Power	3 HP
Capacity (BTU/Hr)	20520
Displacement(cc/rev)	46.6
Cooling Capacity(W) ^(a)	6014
Input Power(W) ^(a)	2791
RLA(A) ^(a)	9.5
Cooling COP(W/W) ^(a)	2.15
Power Supply	208-230V/3~/60Hz
Min. Operating Voltage(V)	187
Max. Operating Voltage(V)	253
LRA(A)	88
Max. Operating Current(A) ^(b)	14.1
Rated Speed(r/min) ^(a)	3500
Compressor Weight (With Oil)(kg)	30
Oil Type	POE
Oil Kinematic Viscosity(cSt, 40°C)	32
Oil Density(kg/L, 20°C)	0.977
Primary Charge(L)	1.4
Recharge(L)	1.25
Oil Circulation Rate ^(a)	≤1%
Rated Sound(Sound Power)(dBA) ^(c)	73
Max. Operating Sound in Running Envelope (Sound Power)(dBA)	78
Vibration Displacement Peak-Peak(mm) ^(d)	≤0.09
Moisture(mg)	≤500
Impurity(mg)	≤100
LVS(V) ^(e)	177
MOV (V) ^(f)	187
Start Capacitor(μF/V)	/
Start Relay	/
Run Capacitor(μF/V)	/
IP Class of Terminal Box	IP21
Compressor Color	Black

Motor Parameters	
Motor Type	Three-phase asynchronous motor
Motor Pole	2
Motor Insulation Class(°C)	130(B Class)
Line to Line Resistance UV(CS)(Ω, 25°C)	1.006(± 10%)
Line to Line Resistance UW(CR)(Ω, 25°C)	1.012(± 10%)
Line to Line Resistance VW(SR)(Ω, 25°C)	0.992(± 10%)
Dielectric Strength	2000VAC / 1s / 60Hz, Leakage Current≤5mA
Insulation Resistance(MΩ)	≥20
Ground Resistance(Ω)	≤0.1

Safety Operating Limit	
Tightness Test Pressure (MPa)	3.8-4.0
Max. Operating Pressure	
High Side(MPa) Low Side(MPa)	H3.2/L2.0
Compressor FreeSpace(Without Oil)	
High Side(L) Low Side(L)	H1.0/L3.8
Max. Refrigerant Charge(kg)	See Notes
Discharge Temperature Limit(°C)	≤125 (120mm to compressor discharge connection and well insulated)
Start-Stop Interval	See Notes

Performance Condition:

Condition	Condition Description
a	Rated Condition
b	Max. Load Condition, 90% Rated Voltage
c	Rated Condition, A Weighted Sound Power
d	Rated Condition, Max Operating Normal Displacement of Compressor Housing
e	Discharge Pressure and Suction Pressure: Saturated Refrigerant Pressure at 40°C
f	Max. Load Condition

2. Rated Condition, 48 Hours Break-in-Running before implementing Performance and Sound Testing

Item	Rated Condition	Max. Load Condition
E.T.(°C)/C.T.(°C)/S.H.(K)/ S.C.(K)/ A.T.(°C)	-6.7/48.9/11.1/0/35	10/65/11.9/0/46.1
Cooling Capacity Deviation	≥92.5%	-
Power Deviation	≤107.5%	-
COP Deviation	≥92.5%	-

3. Internal Protector

Protection Method	Config	Parameter		
Internal Overload Protector	With	Vendor	Vendor 1	Vendor 2
		Model	37HM408-XX	
		Open Temp.(°C)	125±5	
		Close Temp. (°C)	60±9	
		Short Time Trip	64A 2-10s	A S
Internal Pressure Relieve Valve	With	2.76-3.10MPa		

4. Accessory

Item	Name	P.N.	PCS
1	Grommet	070-0003-00	4
2	Sleeve	010-0014-00	4

5. Compressor Operating Envelope

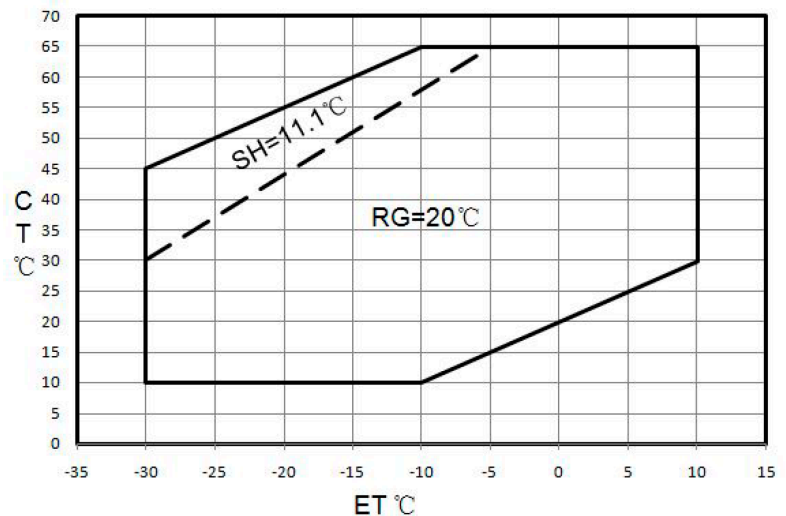

Compressor Performance Sheet

- » Performance Based on Superheat is within the Operating Envelope, Subcooling after Condenser is OK;
- » Performance Calculated by Coefficients of Polynomial is Only Suitable for the Condition within Operating Envelope
- » Capacity, Power can be Calculated by Coefficients of Polynomial

Performance Table										
Item	ET, °C C.T, °C	-30	-25	-20	-15	-10	-5	0	5	10
Cooling Cap. (W)	65					4153	4982	5979	7170	8580
	60				3735	4519	5455	6570	7888	9435
	55			3278	4016	4891	5927	7152	8591	10269
	50		2801	3492	4304	5262	6393	7722	9276	11079
	45	2325	2967	3715	4595	5630	6849	8276	9937	11858
	40	2462	3145	3944	4883	5990	7290	8808	10571	12604
	35	2612	3329	4172	5166	6338	7712	9315	11173	13311
	30	2771	3516	4397	5439	6668	8111	9793	11739	13976
	25	2935	3701	4613	5697	6978	8482	10236	12264	
	20	3099	3880	4817	5935	7262	8821	10640		
10	3412	4202	5169	6338	7735					
Power (W)	65					3462	3699	3876	4003	4092
	60				2992	3237	3422	3557	3654	3722
	55			2567	2817	3007	3149	3251	3326	3384
	50		2183	2437	2631	2776	2883	2962	3024	3081
	45	1840	2095	2291	2438	2546	2628	2692	2751	2815
	40	1790	1985	2131	2240	2321	2386	2445	2509	2589
	35	1711	1855	1961	2040	2103	2161	2224	2302	2408
	30	1607	1709	1784	1843	1897	1956	2031	2133	2273
	25	1481	1549	1602	1650	1704	1773	1870	2005	
	20	1335	1380	1420	1465	1528	1617	1744		
10	999	1023	1063	1132	1239					

Notes

- » It is not allowed to perform vacuum in the system by using the refrigeration compressor. The compressor can start only after the refrigerant charged. In some cases, such as on the field site, if it is limited by the situation that can't charge the required volume of refrigerant, 50% of the required refrigerant is charged necessary before the compressor starts. Double check the system and make sure everything is under safe status, then power on the compressor and charge the remained refrigerant when the compressor is running.
- » It is not allowed to charge the refrigerant from the suction or discharge line closes to the compressor. The charge port should be arranged on the connection pipe of suction line accumulator or receiver, which is on the side far away to the compressor, to avoid the liquid refrigerant flood back.
- » Refrigerant charge limitation: the ratio between the weight of oil and refrigerant should be ≥ 0.4 .
- » It is not allowed to vacuum by compressor, not allowed to run the compressor without refrigerant, and not allowed to run the compressor on the reversed direction for long duration.
- » The compressor can only work with approved refrigerant.
- » The compressor is not allowed to work outside its envelope, the system should guarantee the suction line superheat and avoid the liquid refrigerant flood back.
- » When the suction and discharge plugs are removed, the assembly and brazing should be done in 15 minutes.
- » The frequently start/stop should be avoided. The suggested minimum continuous running time is 10 minutes to guarantee the safe oil level ($\geq 50\%$ initial charge volume), the suggested minimum interval duration between start and stop is 3 minutes.
- » The deviation of supplied voltage should be less than $\pm 10\%$ of rated voltage.
- » A 70W crankcase heater is recommended to avoid the refrigerant migration during the off circle and flood start. The crankcase heater should be power on 12 hours earlier than the first start or restart after long duration off.
- » The system should be equipped with necessary protection devices, such as pressure, temperature, oil return, overcurrent and phase fault, etc.
- » The compressor is not allowed to lay down or place upside down during transportation, stock and installation. The maximum inclination is 15° when the compressor is running.

Ten Coefficients of Polynomial			
Expression	$z = p_0 + p_1*x + p_2*y + p_3*x^2 + p_4*x*y + p_5*y^2 + p_6*x^3 + p_7*x^2*y + p_8*x*y^2 + p_9*y^3$		
Description	z: Cooling Capacity(W) or Power (W) Specially: Heating Capacity(W)=Cooling Capacity(W)+Power (W) x: E.T. °C y: C.T. °C p0~p9: Coefficients of Polynomial		
Cooling Cap. Factor	Value	Power Factor	Value
p0	11786.999	p0	1652.883147
p1	434.937524	p1	76.870181
p2	-35.545384	p2	-13.958497
p3	6.514005	p3	1.84632
p4	-1.657572	p4	-3.065844
p5	-1.20541	p5	1.009231
p6	0.034398	p6	0.014277
p7	-0.04065	p7	-0.043665
p8	-0.025872	p8	0.036091
p9	0.005809	p9	-0.004128

Drawings
Outline Drawing

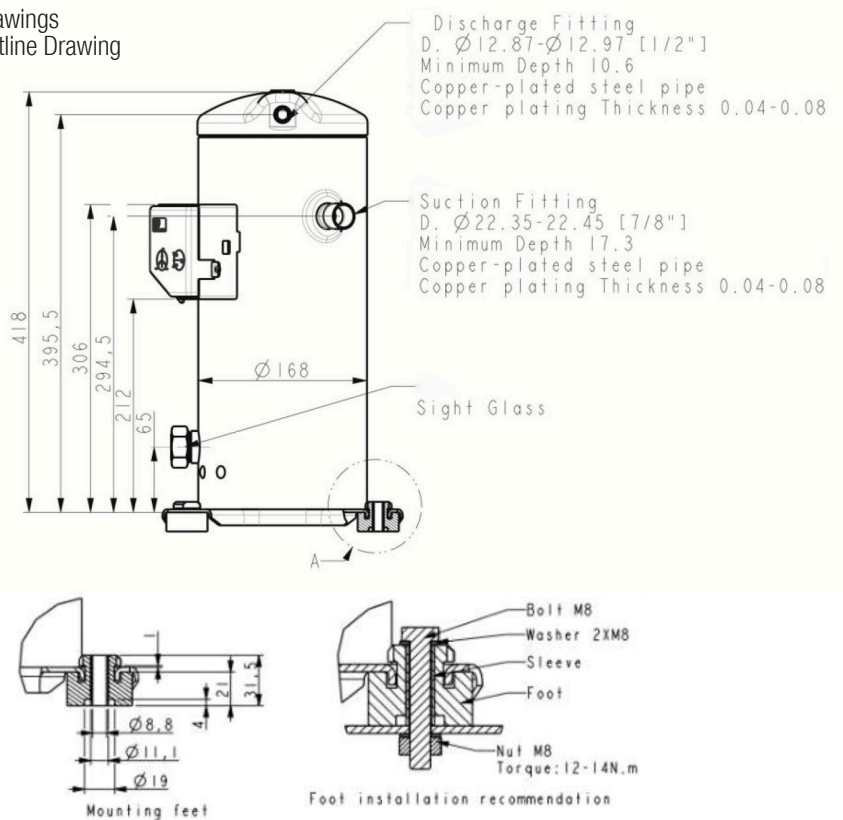

Grommet Drawing

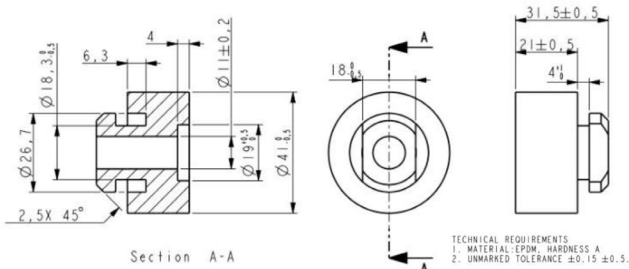

Sleeve Drawing

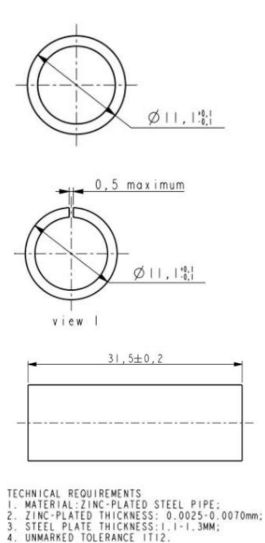

T-Box Layout Standard

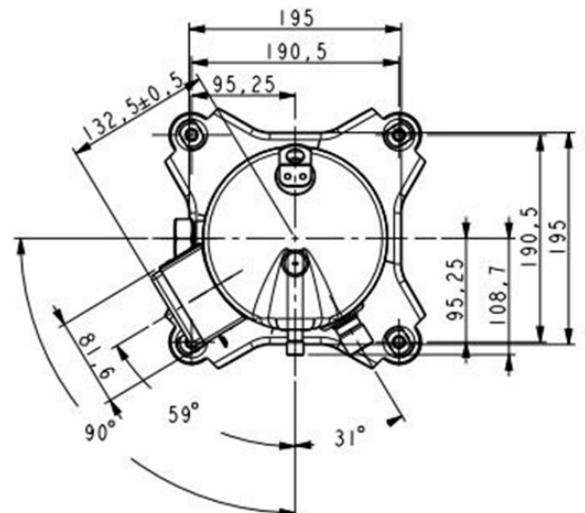
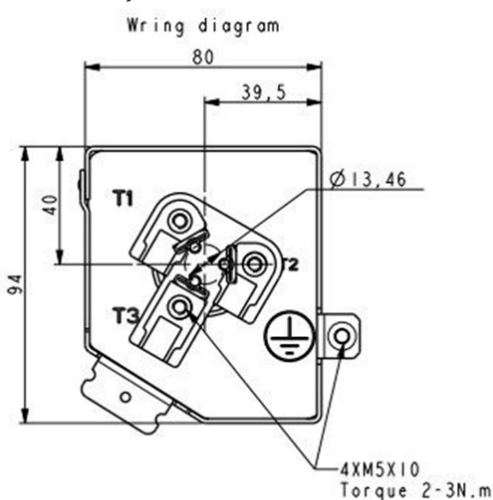

Application

- » See Details in the YM serial MBP refrigerant scroll compressor application manual