

Basic Specification

Model	YM60E7S-100 (Including Extended Model)
Type	Low Side Shell Design Scroll Compressor
Application	Medium Temp. Refrigeration
Refrigerant	R404A
Power	3.5 HP
Capacity (BTU/Hr)	24983
Displacement(cc/rev)	58
Cooling Capacity(W) ^(a)	7320
Input Power(W) ^(a)	3864
RLA(A) ^(a)	12.3
Cooling COP(W/W) ^(a)	1.89
Power Supply	208-230V/3~/60Hz
Min. Operating Voltage(V)	187
Max. Operating Voltage(V)	253
LRA(A)	136
Max. Operating Current(A) ^(b)	18.69
Rated Speed(r/min) ^(a)	3500
Compressor Weight (With Oil)(kg)	31
Oil Type	POE
Oil Kinematic Viscosity(cSt, 40°C)	32
Oil Density(kg/L, 20°C)	0.977
Primary Charge(L)	1.6
Recharge(L)	1.45
Oil Circulation Rate ^(a)	≤1%
Rated Sound(Sound Power)(dBA) ^(c)	75
Max. Operating Sound in Running Envelope (Sound Power)(dBA)	80
Vibration Displacement Peak-Peak(mm) ^(d)	≤0.1
Moisture(mg)	≤500
Impurity(mg)	≤100
LVS(V) ^(e)	177
MOV (V) ^(f)	187
Start Capacitor(μF/V)	/
Start Relay	/
Run Capacitor(μF/V)	/
IP Class of Terminal Box	IP21
Compressor Color	Black

Motor Parameters

Motor Type	Three-phase asynchronous motor
Motor Pole	2
Motor Insulation Class(°C)	130(B Class)
Line to Line Resistance UV(CS)(Ω, 25°C)	0.572(± 10%)
Line to Line Resistance UW(CR)(Ω, 25°C)	0.572(± 10%)
Line to Line Resistance VW(SR)(Ω, 25°C)	0.572(± 10%)
Dielectric Strength	2000VAC / 1s / 50Hz or 60Hz, Leakage Current≤5mA
Insulation Resistance(MΩ)	≥20
Ground Resistance(Ω)	≤0.1

Safety Operating Limit

Tightness Test Pressure (MPa)	3.8-4.0
Max. Operating Pressure	
High Side(MPa) Low Side(MPa)	H3.2/L2.0
Compressor FreeSpace(Without Oil)	
High Side(L) Low Side(L)	H1.0/L3.6
Max. Refrigerant Charge(kg)	See Notes
Discharge Temperature Limit(°C)	≤125 (120mm to compressor discharge connection and well insulated)
Start-Stop Interval	See Notes

Performance Condition:

Condition	Condition Description
a	Rated Condition
b	Max. Load Condition, 90% Rated Voltage
c	Rated Condition, A Weighted Sound Power
d	Rated Condition, Max Operating Normal Displacement of Compressor Housing
e	Discharge Pressure and Suction Pressure: Saturated Refrigerant Pressure at 40°C
f	Max. Load Condition

2. Rated Condition, 48 Hours Break-in-Running before implementing Performance and Sound Testing

Item	Rated Condition	Max. Load Condition
E.T.(°C)/C.T.(°C)/S.H.(K)/ S.C.(K)/ A.T.(°C)	-6.7/48.9/11.1/0/35	10/65/11.9/0/46.1
Cooling Capacity Deviation	≥92.5%	-
Power Deviation	≤107.5%	-
COP Deviation	≥92.5%	-

3. Internal Protector

Protection Method	Config	Parameter		
Internal Overload Protector	With	Vendor	Vendor 1	Vendor 2
		Model	UP28LA05B-XX	
		Open Temp.(°C)	125±5	
		Close Temp. (°C)	70±10	
		Short Time Trip	103A 3-10s	A S
Internal Pressure Relieve Valve	With	2.76-3.10MPa		

4. Accessory

Item	Name	P.N.	PCS
1	Grommet	070-0003-00	4
2	Sleeve	010-0014-00	4

5. Compressor Operating Envelope

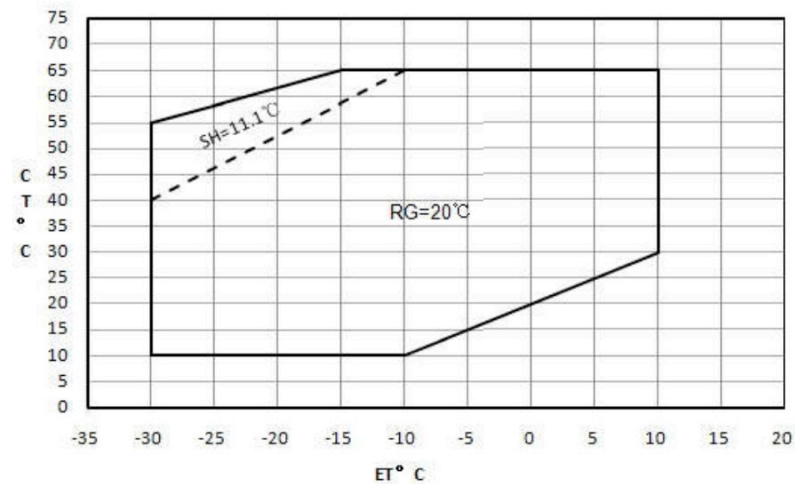

EVI control logic (only for the compressor with EVI module)

- » Recommend system subcooling 5K
- » $DLT \leq 95^\circ\text{C}$, control superheat of injection line=5K
- » $DLT > 95^\circ\text{C}$, control $DLT = 95^\circ\text{C}$
- » Max injection pressure $\leq 2.0\text{MPa}$

Compressor Performance Sheet

- » Performance Based on Superheat is within the Operating Envelope, Subcooling after Condenser is OK;
- » Performance Calculated by Coefficients of Polynomial is Only Suitable for the Condition within Operating Envelope
- » Capacity, Power can be Calculated by Coefficients of Polynomial

Performance Table					
Item	E.T.(°C)	-20	-10	0	10
	C.T.(°C)				
Heating Cap.(W) (Cooling Cap.)	50				
	40				
	30				
Cooling Cap. (W)	50	4642	6761	9584	13366
	40	5424	7930	11319	15845
	30	6117	9010	12965	18236
Power(W)	50	3429	3761	4061	4316
	40	2875	3157	3425	3666
	30	2417	2662	2909	3148

Ten Coefficients of Polynomial			
Expression	$z = p_0 + p_1*x + p_2*y + p_3*x^2 + p_4*x*y + p_5*y^2 + p_6*x^3 + p_7*x^2*y + p_8*x*y^2 + p_9*y^3$		
Description	z: Cooling Capacity(W) or Power (W) Specially: Heating Capacity(W)=Cooling Capacity(W)+Power (W) x: E.T. °C y: C.T. °C p0~p9: Coefficients of Polynomial		
Cooling Cap. Factor	Value	Power Factor	Value
p0	18416.505356	p0	1949.861996
p1	653.339402	p1	28.3335
p2	-215.510684	p2	19.996777
p3	9.25589	p3	0.222118
p4	-6.538096	p4	-0.304701
p5	1.650233	p5	0.332465
p6	0.042276	p6	-0.001884
p7	-0.089258	p7	-0.008854
p8	-0.000163	p8	0.005926
p9	-0.01746	p9	0.002238

Notes: Coefficients of polynomial are based on the fitting results of some sample data, which can be used as a reference of compressor selection, but cannot completely eliminate customer's test.

Notes

- » It is not allowed to perform vacuum in the system by using the refrigeration compressor. The compressor can start only after the refrigerant charged. In some cases, such as on the field site, if it is limited by the situation that can't charge the required volume of refrigerant, 50% of the required refrigerant is charged necessary before the compressor starts. Double check the system and make sure everything is under safe status, then power on the compressor and charge the remained refrigerant when the compressor is running.
- » It is not allowed to charge the refrigerant from the suction or discharge line closes to the compressor. The charge port should be arranged on the connection pipe of suction line accumulator or receiver, which is on the side far away to the compressor, to avoid the liquid refrigerant flood back.
- » Refrigerant charge limitation: the ratio between the weight of oil and refrigerant should be ≥ 0.4 .
- » It is not allowed to vacuum by compressor, not allowed to run the compressor without refrigerant, and not allowed to run the compressor on the reversed direction for long duration.
- » The compressor can only work with approved refrigerant.
- » The compressor is not allowed to work outside its envelope, the system should guarantee the suction line superheat and avoid the liquid refrigerant flood back.
- » When the suction and discharge plugs are removed, the assembly and brazing should be done in 15 minutes.
- » The frequently start/stop should be avoided. The suggested minimum continuous running time is 10 minutes to guarantee the safe oil level ($\geq 50\%$ initial charge volume), the suggested minimum interval duration between start and stop is 3 minutes.
- » The deviation of supplied voltage should be less than $\pm 10\%$ of rated voltage.
- » A 70W crankcase heater is recommended to avoid the refrigerant migration during the off circle and flood start. The crankcase heater should be power on 12 hours earlier than the first start or restart after long duration off.
- » The system should be equipped with necessary protection devices, such as pressure, temperature, oil return, over current and phase fault, etc.
- » The compressor is not allowed to lay down or place upside down during transportation, stock and installation. The maximum inclination is 15° when the compressor is running.

Drawings
Outline Drawing

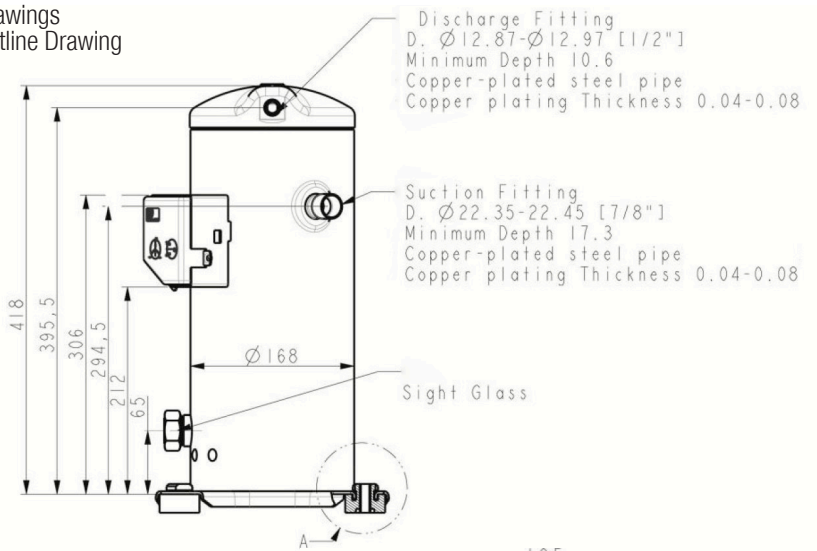

Grommet Drawing

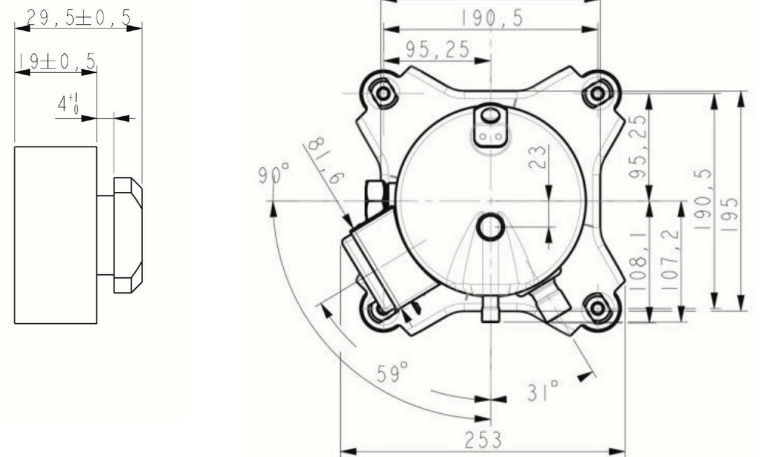
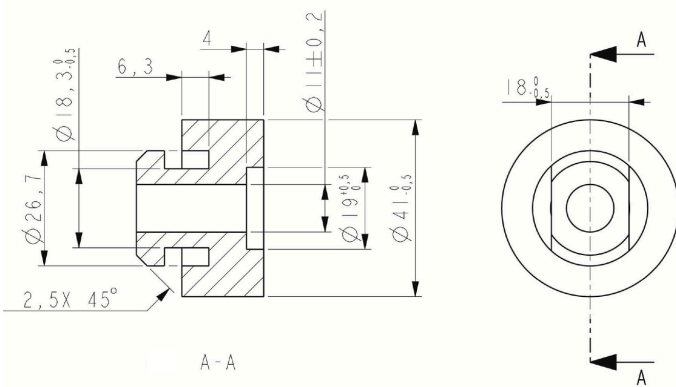

T-Box Layout Standard

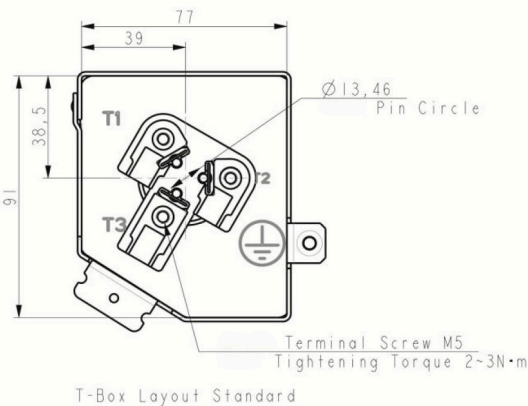

Sleeve Drawing

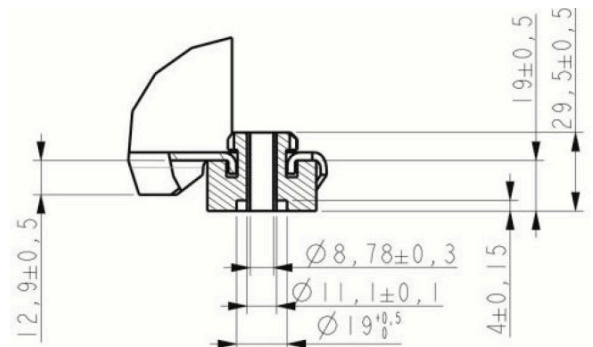
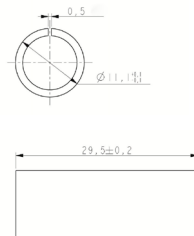

Application

- » See Details in the YM serial MBP refrigerant scroll compressor application manual