

Basic Specification	
Model	YM70E3G-100 (Including Extended Model)
Type	Low Side Shell Design Scroll Compressor
Application	Medium Temp. Refrigeration
Power	4 HP
Capacity (BTU/Hr)	28334
Refrigerant	R-404A
Displacement(cc/rev)	67.8
Cooling Capacity(W) ^(a)	8304
Input Power(W) ^(a)	4489
RLA(A) ^(a)	21.5
Cooling COP(W/W) ^(a)	1.85
Power Supply	208-230V/1~/60Hz
Min. Operating Voltage(V)	187
Max. Operating Voltage(V)	253
LRA(A)	140
Max. Operating Current(A) ^(b)	34
Rated Speed(r/min) ^(a)	3500
Compressor Weight (With Oil)(kg)	38
Oil Type	POE
Oil Kinematic Viscosity(cSt, 40°C)	32
Oil Density(kg/L, 20°C)	0.977
Primary Charge(L)	1.6
Recharge(L)	1.45
Oil Circulation Rate ^(a)	≤1%
Rated Sound(Sound Power)(dBA) ^(c)	75
Max. Operating Sound in Running Envelope (Sound Power)(dBA)	80
Vibration Displacement Peak-Peak(mm) ^(d)	≤0.1
Moisture(mg)	≤500
Impurity(mg)	≤100
LVS(V) ^(e)	177
MOV (V) ^(f)	187
Start Capacitor(μF/V)	250
Start Relay	HLR3800-3F3C
Run Capacitor(μF/V)	100/450

Motor Parameters	
Motor Type	Single-phase asynchronous motor
Motor Pole	2
Motor Insulation Class(°C)	130(B Class)
Line to Line Resistance UV(CS)(Ω, 25°C)	0.777(± 10%)
Line to Line Resistance UW(CR)(Ω, 25°C)	0.395(± 10%)
Line to Line Resistance VW(SR)(Ω, 25°C)	1.172(± 10%)
Dielectric Strength	2000VAC / 1s / 50Hz, Leakage Current≤5mA
Insulation Resistance(MΩ)	≥20
Ground Resistance(Ω)	≤0.1

Safety Operating Limit	
Tightness Test Pressure (MPa)	3.8-4.0
Max. Operating Pressure	
High Side(MPa) Low Side(MPa)	H3.2/L2.0
Compressor FreeSpace(Without Oil)	
High Side(L) Low Side(L)	H1.0/L3.7
Max. Refrigerant Charge(kg)	See Notes
Discharge Temperature Limit(°C)	≤125 (120mm to compressor discharge connection and well insulated)
Start-Stop Interval	See Notes

Performance Condition:

Condition	Condition Description
a	Rated Condition
b	Max. Load Condition, 90% Rated Voltage
c	Rated Condition, A Weighted Sound Power
d	Rated Condition, Max Operating Normal Displacement of Compressor Housing
e	Discharge Pressure and Suction Pressure: Saturated Refrigerant Pressure at 40°C
f	Max. Load Condition

2. Rated Condition, 48 Hours Break-in-Running before implementing Performance and Sound Testing

Item	Rated Condition	Max. Load Condition
E.T.(°C)/C.T.(°C)/S.H.(K)/ S.C.(K)/A.T.(°C)	-6.7/48.9/11.1/0/35	10/65/11.9/0/46.1
Cooling Capacity Deviation	≥92.5%	-
Power Deviation	≤107.5%	-
COP Deviation	≥92.5%	-

3. Internal Protector

Protection Method	Config	Parameter		
Internal Overload Protector	With	Vendor	Vendor 1	Vendor 2
		Model	UP16QC051A-XX	
		Open Temp.(°C)	150±5	
		Close Temp. (°C)	80±9	
		Short Time Trip	155A 3-10s	A s
Internal Pressure Relieve Valve	With	-MPa		

4. Accessory

Item	Name	P.N.	PCS
1	Grommet	070-0003-00	4
2	Sleeve	010-0014-00	4
3	StartBox	110-0076-10	1

5. Compressor Operating Envelope

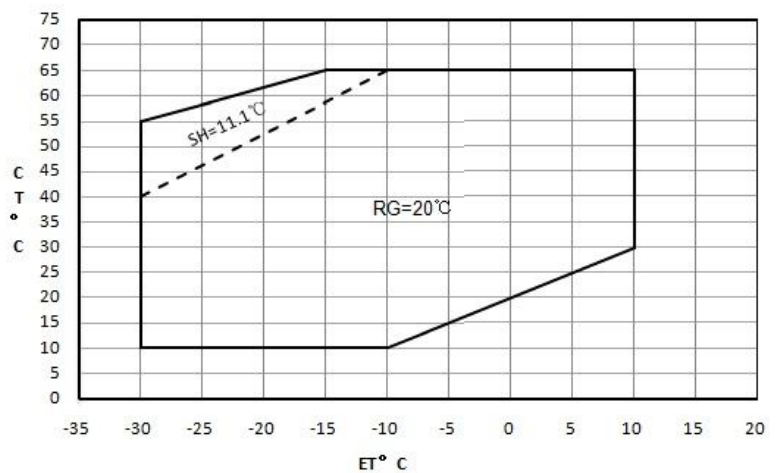

EVI control logic(only for EVI module)

- » Recommend system subcooling 5K
- » DLT≤95°C,control superheat of injection line=5K
- » DLT>95°C,control DLT=95°C
- » Max injection pressure≤2.0MPa

Compressor Performance Sheet

- » Performance Based on Superheat is within the Operating Envelope, Subcooling after Condenser is OK;
- » Performance Calculated by Coefficients of Polynomial is Only Suitable for the Condition within Operating Envelope
- » Capacity, Power can be Calculated by Coefficients of Polynomial

Performance Table					
Item	E.T.(°C)	-20	-10	0	10
	C.T.(°C)				
Heating Cap.(W) (Cooling Cap.)	50				
	40				
	30				
Cooling Cap. (W)	50	5440	7923	11231	15663
	40	6356	9293	13265	18569
	30	7169	10559	15194	21370
Power(W)	50	3948	4314	4644	4925
	40	3336	3648	3943	4209
	30	2831	3102	3375	3638

Ten Coefficients of Polynomial			
Expression	$z = p_0 + p_1*x + p_2*y + p_3*x^2 + p_4*x*y + p_5*y^2 + p_6*x^3 + p_7*x^2*y + p_8*x*y^2 + p_9*y^3$		
Description	z: Cooling Capacity(W) or Power (W) Specially: Heating Capacity(W)=Cooling Capacity(W)+Power (W) x: E.T. °C y: C.T. °C p0~p9: Coefficients of Polynomial		
Cooling Cap. Factor	Value	Power Factor	Value
p0	21582.231857	p0	2316.739939
p1	765.645935	p1	31.231531
p2	-252.556143	p2	22.04636
p3	10.846942	p3	0.244866
p4	-7.661969	p4	-0.335914
p5	1.933902	p5	0.366519
p6	0.049543	p6	-0.002076
p7	-0.104601	p7	-0.009759
p8	-0.000191	p8	0.006533
p9	-0.020462	p9	0.002469

Notes

- » It is not allowed to perform vacuum in the system by using the refrigeration compressor. The compressor can start only after the refrigerant charged. In some cases, such as on the field site, if it is limited by the situation that can't charge the required volume of refrigerant, 50% of the required refrigerant is charged necessary before the compressor starts. Double check the system and make sure everything is under safe status, then power on the compressor and charge the remained refrigerant when the compressor is running.
- » It is not allowed to charge the refrigerant from the suction or discharge line closes to the compressor. The charge port should be arranged on the connection pipe of suction line accumulator or receiver, which is on the side far away to the compressor, to avoid the liquid refrigerant flood back.
- » Refrigerant charge limitation: the ratio between the weight of oil and refrigerant should be ≥ 0.4 .
- » It is not allowed to vacuum by compressor, not allowed to run the compressor without refrigerant, and not allowed to run the compressor on the reversed direction for long duration.
- » The compressor can only work with approved refrigerant.
- » The compressor is not allowed to work outside its envelope, the system should guarantee the suction line superheat and avoid the liquid refrigerant flood back.
- » When the suction and discharge plugs are removed, the assembly and brazing should be done in 15 minutes.
- » The frequently start/stop should be avoided. The suggested minimum continuous running time is 10 minutes to guarantee the safe oil level ($\geq 50\%$ initial charge volume), the suggested minimum interval duration between start and stop is 3 minutes.
- » The deviation of supplied voltage should be less than $\pm 10\%$ of rated voltage.
- » A 70W crankcase heater is recommended to avoid the refrigerant migration during the off circle and flood start. The crankcase heater should be power on 12 hours earlier than the first start or restart after long duration off.
- » The system should be equipped with necessary protection devices, such as pressure, temperature, oil return, overcurrent and phase fault, etc.
- » The compressor is not allowed to lay down or place upside down during transportation, stock and installation. The maximum inclination is 15° when the compressor is running.

Drawings

Outline Drawing

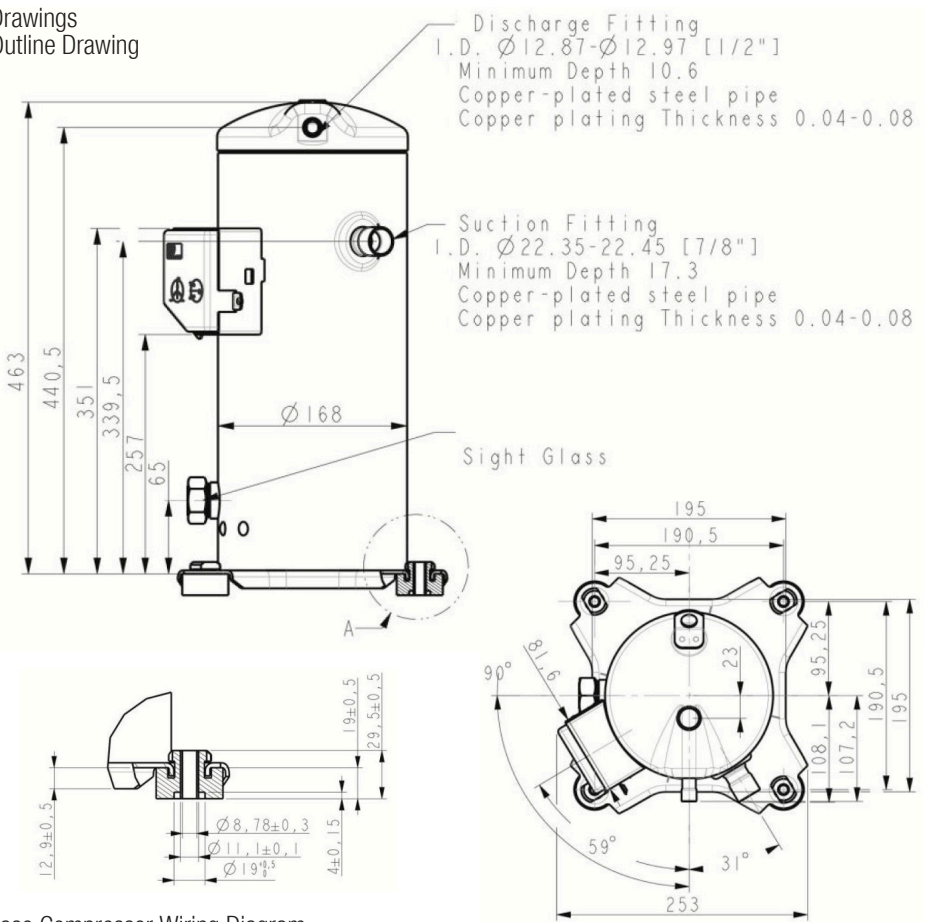

Notes: Coefficients of polynomial are based on the fitting results of some sample data, which can be used as a reference of compressor selection, but cannot completely eliminate customer's test.

Grommet Drawing 070-0003-00

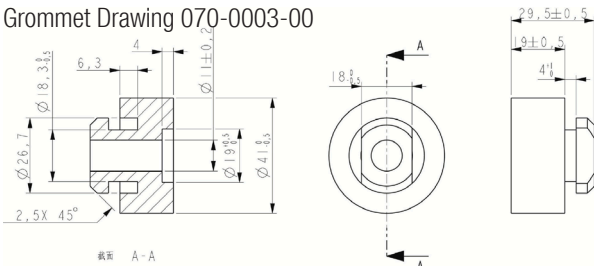

Sleeve Drawing 010-0014-00

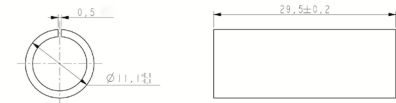

T-Box Layout Standard

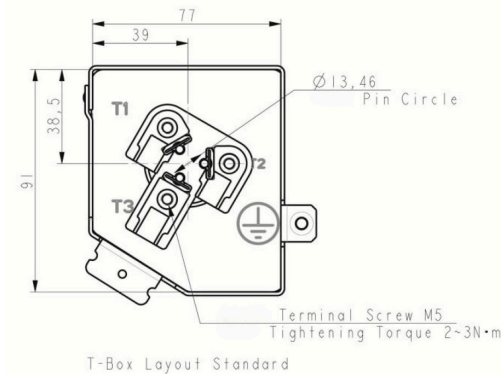

Single Phase Compressor Wiring Diagram

Model	YW75A(T)2-YW80A(T)2-**** YW38J2-YW55J2-**** YW75C2-****	YW102A(T)2-YW110A(T)2-**** YW80J2-**** YW10C2-**** YW95C3-**** YH104A(T)2-**** YH104A(T)2-YH128A(T)2-**** YW80A(E)2-YW70A(E)2-**** YF25A(E)2-YF28A(E)2-**** YF28A(E)2-YF38A(E)2-****	YM34A(E)3-YM49A(E)3-**** YF13A(E)3-YF20A(E)3-**** YW38J3-YW55J3-**** YH69A(T)3-YH89A(T)3-****	YW132A(T)2-**** YW132C2-**** YW135C2-**** YF35A(E)2/3A-**** YH118A(T)2-YH128A(T)2-**** YH118C2(E)2-YH128C2(E)2-**** YH118C2(E)2-YH128C2(E)2-**** YH118C2(E)2-YH128C2(E)2-**** YH118C2(E)2-YH128C2(E)2-**** YH118C2(E)2-YH128C2(E)2-****
Start Cap	Capacity(μf) Voltage(V)	250 330	160 330	250 330
Run Cap	Capacity(μf) Voltage(V)	60 450	80 450	100 500
Relay		HLR3800-3E3D	HLR3800-3H3D	HLR3800-4A13D HLR3800-3F3C

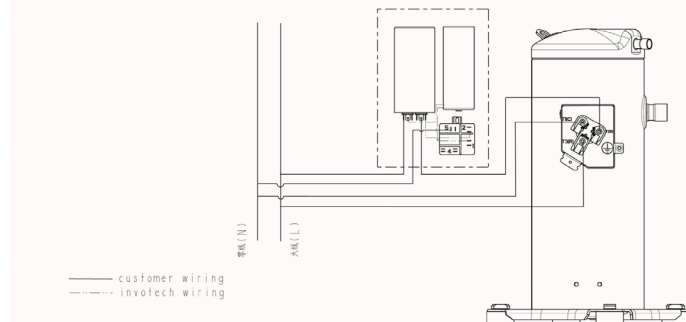

Application

- » See Details in the YM serial MBP refrigerant scroll compressor application manual