

Basic Specification	
Model	YM86E3S-100 (Including Extended Model)
Type	Low Side Shell Design Scroll Compressor
Application	Medium Temp. Refrigeration
Power	5 HP
Capacity (BTU/Hr)	34803
Refrigerant	R-404A
Displacement(cc/rev)	83.3
Cooling Capacity(W) ^(a)	10200
Input Power(W) ^(a)	5514
RLA(A) ^(a)	26.4
Cooling COP(W/W) ^(a)	1.85
Power Supply	208-230V/1~/60Hz
Min. Operating Voltage(V)	187
Max. Operating Voltage(V)	253
LRA(A)	140
Max. Operating Current(A) ^(b)	40.1
Rated Speed(r/min) ^(a)	3500
Compressor Weight (With Oil)(kg)	38
Oil Type	POE
Oil Kinematic Viscosity(cSt, 40°C)	32
Oil Density(kg/L, 20°C)	0.977
Primary Charge(L)	1.6
Recharge(L)	1.45
Oil Circulation Rate ^(a)	≤1%
Rated Sound(Sound Power)(dBA) ^(c)	75
Max. Operating Sound in Running Envelope (Sound Power)(dBA)	80
Vibration Displacement Peak-Peak(mm) ^(d)	≤0.1
Moisture(mg)	≤500
Impurity(mg)	≤100
LVS(V) ^(e)	177
MOV (V) ^(f)	187
Start Capacitor(μF/V)	250
Start Relay	HLR3800-3F3C
Run Capacitor(μF/V)	100/450
IP Class of Terminal Box	IP21
Compressor Color	Black

Motor Parameters	
Motor Type	Single-phase asynchronous motor
Motor Pole	2
Motor Insulation Class(°C)	130(B Class)
Line to Line Resistance UV(CS)(Ω, 25°C)	0.777(± 10%)
Line to Line Resistance UW(CR)(Ω, 25°C)	0.395(± 10%)
Line to Line Resistance VW(SR)(Ω, 25°C)	1.172(± 10%)
Dielectric Strength	2000VAC / 1s / 50Hz, Leakage Current≤5mA
Insulation Resistance(MΩ)	≥20
Ground Resistance(Ω)	≤0.1

Safety Operating Limit	
Tightness Test Pressure (MPa)	3.8-4.0
Max. Operating Pressure	
High Side(MPa)	H3.2/L2.0
Low Side(MPa)	
Compressor FreeSpace(Without Oil)	
High Side(L)	H1.0/L3.7
Low Side(L)	
Max. Refrigerant Charge(kg)	See Notes
Discharge Temperature Limit(°C)	≤125 (120mm to compressor discharge connection and well insulated)
Start-Stop Interval	See Notes

Performance Condition:

Condition	Condition Description
a	Rated Condition
b	Max. Load Condition, 90% Rated Voltage
c	Rated Condition, A Weighted Sound Power
d	Rated Condition, Max Operating Normal Displacement of Compressor Housing
e	Discharge Pressure and Suction Pressure: Saturated Refrigerant Pressure at 40°C
f	Max. Load Condition

2. Rated Condition, 48 Hours Break-in-Running before implementing Performance and Sound Testing

Item	Rated Condition	Max. Load Condition
E.T.(°C)/C.T.(°C)/S.H.(K)/ S.C.(K)/ A.T.(°C)	-6.7/48.9/11.1/0/35	10/65/11.9/0/46.1
Cooling Capacity Deviation	≥92.5%	-
Power Deviation	≤107.5%	-
COP Deviation	≥92.5%	-

3. Internal Protector

Protection Method	Config	Parameter		
Internal Overload Protector	With	Vendor	Vendor 1	Vendor 2
		Model	UP16QC051A-XX	
		Open Temp.(°C)	150±5	
		Close Temp. (°C)	80±9	
		Short Time Trip	155A 3-10s	A S
Internal Pressure Relieve Valve	With	-MPa		

4. Accessory

Item	Name	P.N.	PCS
1	Grommet	070-0003-00	4
2	Sleeve	010-0014-00	4
3	StartBox	110-0076-10	1

5. Compressor Operating Envelope

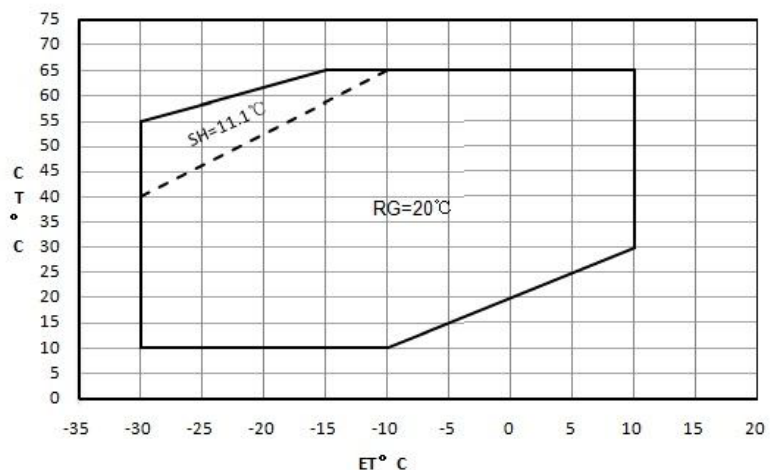

EVI control logic (only for EVI module)

- » Recommend system subcooling 5K
- » DLT≤95°C, control superheat of injection line=5K
- » DLT>95°C, control DLT=95°C
- » Max injection pressure≤2.0MPa

Compressor Performance Sheet

- » Performance Based on Superheat is within the Operating Envelope, Subcooling after Condenser is OK;
- » Performance Calculated by Coefficients of Polynomial is Only Suitable for the Condition within Operating Envelope
- » Capacity, Power can be Calculated by Coefficients of Polynomial

Performance Table					
Item	E.T.(°C)	-20	-10	0	10
	C.T.(°C)				
Heating Cap.(W) (Cooling Cap.)	50				
	40				
	30				
Cooling Cap. (W)	50	6665	9706	13760	19189
	40	7787	11385	16251	22749
	30	8782	12936	18614	26181
Power(W)	50	4859	5309	5715	6061
	40	4106	4490	4853	5180
	30	3485	3817	4153	4477

Ten Coefficients of Polynomial			
Expression	$z = p_0 + p_1 \cdot x + p_2 \cdot y + p_3 \cdot x^2 + p_4 \cdot x \cdot y + p_5 \cdot y^2 + p_6 \cdot x^3 + p_7 \cdot x^2 \cdot y + p_8 \cdot x \cdot y^2 + p_9 \cdot y^3$		
Description	z: Cooling Capacity(W) or Power (W) Specially: Heating Capacity(W)=Cooling Capacity(W)+Power (W) x: E.T. °C y: C.T. °C p0~p9: Coefficients of Polynomial		
Cooling Cap. Factor	Value	Power Factor	Value
p0	26440.6224	p0	2851.164
p1	938.001	p1	38.436
p2	-309.409224	p2	27.132
p3	13.288704	p3	0.301351
p4	-9.38676	p4	-0.413402
p5	2.369244	p5	0.451067
p6	0.060696	p6	-0.002554
p7	-0.128148	p7	-0.012011
p8	-0.000234	p8	0.00804
p9	-0.025068	p9	0.003039

Notes: Coefficients of polynomial are based on the fitting results of some sample data, which can be used as a reference of compressor selection, but cannot completely eliminate customer's test.

Grommet Drawing

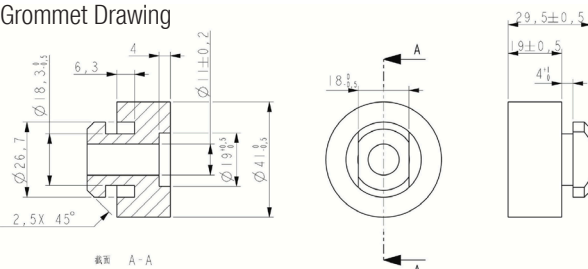

Sleeve Drawing

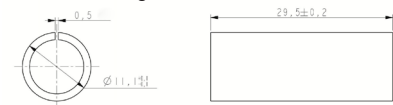

T-Box Layout Standard

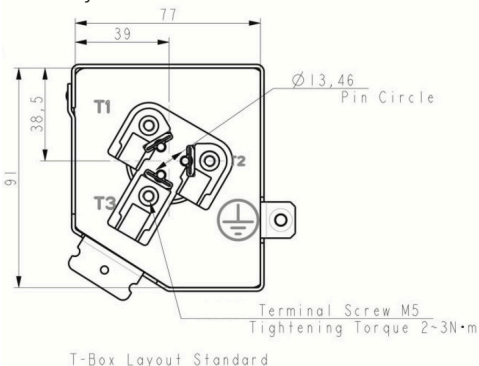

Application

- » See Details in the YM serial MBP refrigerant scroll compressor application manual

Notes

- » It is not allowed to perform vacuum in the system by using the refrigeration compressor. The compressor can start only after the refrigerant charged. In some cases, such as on the field site, if it is limited by the situation that can't charge the required volume of refrigerant, 50% of the required refrigerant is charged necessary before the compressor starts. Double check the system and make sure everything is under safe status, then power on the compressor and charge the remained refrigerant when the compressor is running.
- » It is not allowed to charge the refrigerant from the suction or discharge line closes to the compressor. The charge port should be arranged on the connection pipe of suction line accumulator or receiver, which is on the side far away to the compressor, to avoid the liquid refrigerant flood back.
- » Refrigerant charge limitation: the ratio between the weight of oil and refrigerant should be ≥ 0.4 .
- » It is not allowed to vacuum by compressor, not allowed to run the compressor without refrigerant, and not allowed to run the compressor on the reversed direction for long duration.
- » The compressor can only work with approved refrigerant.
- » The compressor is not allowed to work outside its envelope, the system should guarantee the suction line superheat and avoid the liquid refrigerant flood back.
- » When the suction and discharge plugs are removed, the assembly and brazing should be done in 15 minutes.
- » The frequently start/stop should be avoided. The suggested minimum continuous running time is 10 minutes to guarantee the safe oil level ($\geq 50\%$ initial charge volume), the suggested minimum interval duration between start and stop is 3 minutes.
- » The deviation of supplied voltage should be less than $\pm 10\%$ of rated voltage.
- » A 70W crankcase heater is recommended to avoid the refrigerant migration during the off circle and flood start. The crankcase heater should be power on 12 hours earlier than the first start or restart after long duration off.
- » The system should be equipped with necessary protection devices, such as pressure, temperature, oil return, overcurrent and phase fault, etc.
- » The compressor is not allowed to lay down or place upside down during transportation, stock and installation. The maximum inclination is 15° when the compressor is running.

Drawings
Outline Drawing

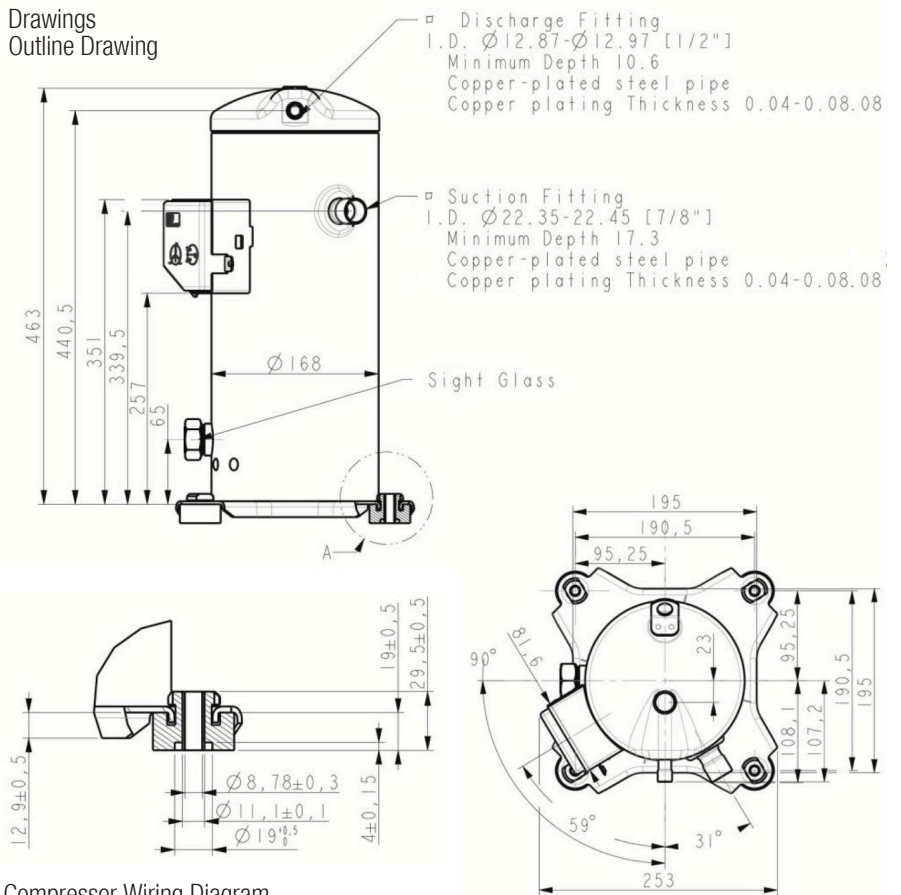

Single Phase Compressor Wiring Diagram

Model	YW75A(T)2-YW80A(T)2* YW38J2-YW55J2* YW75C2* YH69A(T)2-YH89A(T)2* YM34A(E)2-YM49A(E)2* YM13A(E)2-YM20A(E)2*	YW102A(T)2-YW110A(T)2* YW80J2* YH95C3* YH104A(T)2-YH120A(T)2* YH60A(E)2-YH70A(E)2* YF25A(E)2-YF29A(E)2* YF25A(E)3-YF29A(E)3*	YM34A(E)3-YM49A(E)3* YF13A(E)3-YF20A(E)3* YW38J3-YW55J3* YH69A(T)3-YH89A(T)3*	YW150A(T)2* YW130C2* YW130E2* YH110A(T)2-YH120A(T)2* YH110A(E)2-YH120A(E)2* YH110A(E)3-YH120A(E)3* YH110A(E)3-YH120A(E)3*
Start Cap	160	250	160	250
Voltage(V)	330	330	330	330
Run Cap	60	60	60	100
Voltage(V)	450	450	450	500
Relay	HLR3800-3E3D	HLR3800-3H3D	HLR3800-4A13D	HLR3800-3F3C

