

Basic Specification	
Model	YM86E7S-100 (Including Extended Model)
Type	Low Side Shell Design Scroll Compressor
Application	Medium Temp. Refrigeration
Power	5 HP
Capacity (BTU/Hr)	35161
Refrigerant	R404A
Displacement(cc/rev)	83.3
Cooling Capacity(W) ^(a)	10434
Input Power(W) ^(a)	5198
RLA(A) ^(a)	16.6
Cooling COP(W/W) ^(a)	2
Power Supply	208-230V/3~/60Hz
Min. Operating Voltage(V)	187
Max. Operating Voltage(V)	253
LRA(A)	136
Max. Operating Current(A) ^(b)	25.2
Rated Speed(r/min) ^(a)	3500
Compressor Weight (With Oil)(kg)	31.8
Oil Type	POE
Oil Kinematic Viscosity(cSt, 40°C)	32
Oil Density(kg/L, 20°C)	0.977
Primary Charge(L)	1.6
Recharge(L)	1.45
Oil Circulation Rate ^(a)	≤1%
Rated Sound(Sound Power)(dBA) ^(c)	76
Max. Operating Sound in Running Envelope (Sound Power)(dBA)	81
Vibration Displacement Peak-Peak(mm) ^(d)	≤0.1
Moisture(mg)	≤500
Impurity(mg)	≤100
LVS(V) ^(e)	177
MOV (V) ^(f)	187
Start Capacitor(μF/V)	/
Start Relay	/
Run Capacitor(μF/V)	/
IP Class of Terminal Box	IP21
Compressor Color	Black

Motor Parameters	
Motor Type	Three-phase asynchronous motor
Motor Pole	2
Motor Insulation Class(°C)	130(B Class)
Line to Line Resistance UV(CS)(Ω, 25°C)	0.675(± 10%)
Line to Line Resistance UW(CR)(Ω, 25°C)	0.675(± 10%)
Line to Line Resistance VW(SR)(Ω, 25°C)	0.675(± 10%)
Dielectric Strength	2000VAC / 1s / 60Hz, Leakage Current≤5mA
Insulation Resistance(MΩ)	≥20
Ground Resistance(Ω)	≤0.1

Safety Operating Limit	
Tightness Test Pressure (MPa)	3.8-4.0
Max. Operating Pressure	
High Side(MPa)	H3.2/L2.0
Low Side(MPa)	
Compressor FreeSpace(Without Oil)	
High Side(L)	H1.0/L4.6
Low Side(L)	
Max. Refrigerant Charge(kg)	See Notes
Discharge Temperature Limit(°C)	≤125 (120mm to compressor discharge connection and well insulated)
Start-Stop Interval	See Notes

Condition	Condition Description
a	Rated Condition
b	Max. Load Condition, 90% Rated Voltage
c	Rated Condition, A Weighted Sound Power
d	Rated Condition, Max Operating Normal Displacement of Compressor Housing
e	Discharge Pressure and Suction Pressure: Saturated Refrigerant Pressure at 40°C
f	Max. Load Condition

2. Rated Condition, 48 Hours Break-in-Running before implementing Performance and Sound Testing

Item	Rated Condition	Max. Load Condition
E.T.(°C)/C.T.(°C)/S.H.(K)/S.C.(K)/A.T.(°C)	-6.7/48.9/11.1/0/35	10/65/11.9/0/46.1
Cooling Capacity Deviation	≥92.5%	-
Power Deviation	≤107.5%	-
COP Deviation	≥92.5%	-

3. Internal Protector

Protection Method	Config	Parameter		
Internal Overload Protector	With	Vendor	Vendor 1	Vendor 2
		Model	UP28LA05B-XX	
		Open Temp.(°C)	125±5	
		Close Temp. (°C)	70±10	
		Short Time Trip	103A 3-10s	A S
Internal Pressure Relieve Valve	With	2.76-3.10MPa		

4. Accessory

Item	Name	P.N.	PCS
1	Grommet	070-0003-00	4
2	Sleeve	010-0014-00	4

5. Compressor Operating Envelope

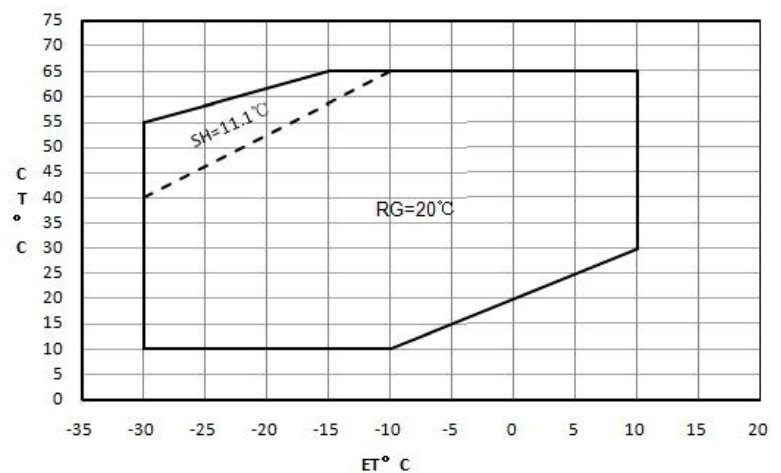

Compressor Performance Sheet

- » Performance Based on Superheat is within the Operating Envelope, Subcooling after Condenser is 0K;
- » Performance Calculated by Coefficients of Polynomial is Only Suitable for the Condition within Operating Envelope
- » Capacity, Power can be Calculated by Coefficients of Polynomial

Performance Table										
Item	E.T.(°C) C.T.(°C)	-30	-25	-20	-15	-10	-5	0	5	10
60			5118	6256	7533	8994	10683	12643	14920	
55	3661	4710	5841	7099	8527	10169	12071	14276	16829	
50	4152	5259	6478	7855	9434	11259	13374	15823	18651	
45	4576	5740	7048	8545	10275	12281	14609	17303	20406	
40	4951	6172	7569	9185	11066	13254	15795	18733	22111	
35	5295	6574	8059	9795	11826	14196	16950	20132	23786	
30	5627	6963	8536	10391	12573	15125	18092	21518	25447	
25	5965	7357	9019	10994	13326	16060	19239	22909		
20	6326	7776	9526	11620	14103	17018	20411			
10	7195	8759	10685	13018	15802					
Power(W)	65			6366	6648	6909	7148	7364	7553	
	60			5554	5828	6088	6330	6553	6755	6934
	55	4552	4822	5083	5335	5574	5798	6007	6198	6369
	50	4173	4415	4652	4882	5103	5313	5509	5691	5855
	45	3827	4044	4259	4469	4674	4870	5056	5231	5391
	40	3511	3705	3900	4093	4284	4469	4647	4816	4974
	35	3225	3398	3574	3752	3930	4106	4278	4444	4601
	30	2965	3118	3279	3444	3611	3780	3947	4112	4272
	25	2729	2865	3011	3165	3324	3488	3653	3818	
	20	2515	2636	2770	2914	3068	3228	3393		
10	2144	2240	2356	2488	2634					

Ten Coefficients of Polynomial			
Expression	$z = p_0 + p_1*x + p_2*y + p_3*x^2 + p_4*x*y + p_5*y^2 + p_6*x^3 + p_7*x^2*y + p_8*x*y^2 + p_9*y^3$		
Description	z: Cooling Capacity(W) or Power (W) Specially: Heating Capacity(W)=Cooling Capacity(W)+Power (W) x: E.T. °C y: C.T. °C p0~p9: Coefficients of Polynomial		
Cooling Cap. Factor	Value	Power Factor	Value
p0	25699.29654	p0	2645.453508
p1	911.7019065	p1	38.44116
p2	-300.734199	p2	27.130404
p3	12.91612351	p3	0.301356
p4	-9.123579813	p4	-0.4134
p5	2.302816598	p5	0.451068
p6	0.058994243	p6	-0.002556
p7	-0.124555065	p7	-0.012012
p8	-0.000227439	p8	0.00804
p9	-0.024365159	p9	0.003036

Notes

- » It is not allowed to perform vacuum in the system by using the refrigeration compressor. The compressor can start only after the refrigerant charged. In some cases, such as on the field site, if it is limited by the situation that can't charge the required volume of refrigerant, 50% of the required refrigerant is charged necessary before the compressor starts. Double check the system and make sure everything is under safe status, then power on the compressor and charge the remained refrigerant when the compressor is running.
- » It is not allowed to charge the refrigerant from the suction or discharge line closes to the compressor. The charge port should be arranged on the connection pipe of suction line accumulator or receiver, which is on the side far away to the compressor, to avoid the liquid refrigerant flood back.
- » Refrigerant charge limitation: the ratio between the weight of oil and refrigerant should be ≥ 0.4 .
- » It is not allowed to vacuum by compressor, not allowed to run the compressor without refrigerant, and not allowed to run the compressor on the reversed direction for long duration.
- » The compressor can only work with approved refrigerant.
- » The compressor is not allowed to work outside its envelope, the system should guarantee the suction line superheat and avoid the liquid refrigerant flood back.
- » When the suction and discharge plugs are removed, the assembly and brazing should be done in 15 minutes.
- » The frequently start/stop should be avoided. The suggested minimum continuous running time is 10 minutes to guarantee the safe oil level ($\geq 50\%$ initial charge volume), the suggested minimum interval duration between start and stop is 3 minutes.
- » The deviation of supplied voltage should be less than $\pm 10\%$ of rated voltage.
- » A 70W crankcase heater is recommended to avoid the refrigerant migration during the off circle and flood start. The crankcase heater should be power on 12 hours earlier than the first start or restart after long duration off.
- » The system should be equipped with necessary protection devices, such as pressure, temperature, oil return, overcurrent and phase fault, etc.
- » The compressor is not allowed to lay down or place upside down during transportation, stock and installation. The maximum inclination is 15° when the compressor is running.

Drawings

Outline Drawing

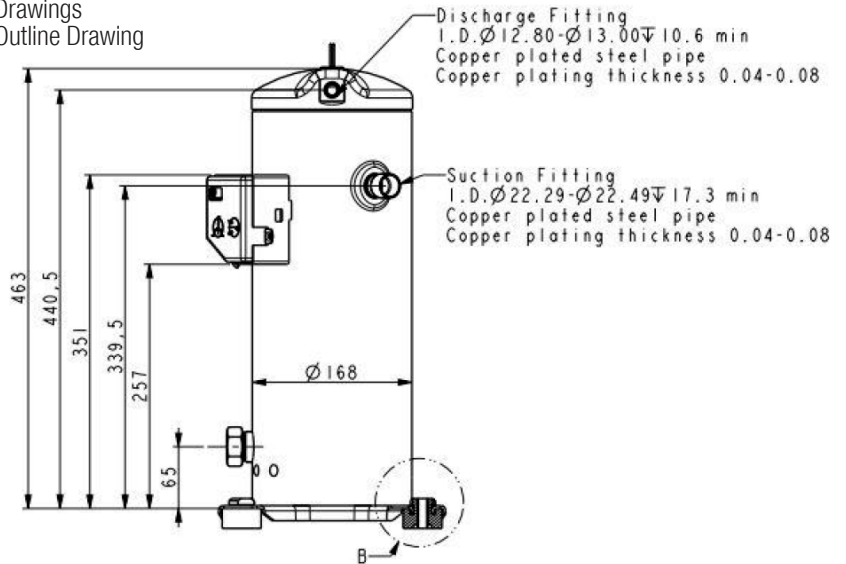

Grommet Drawing

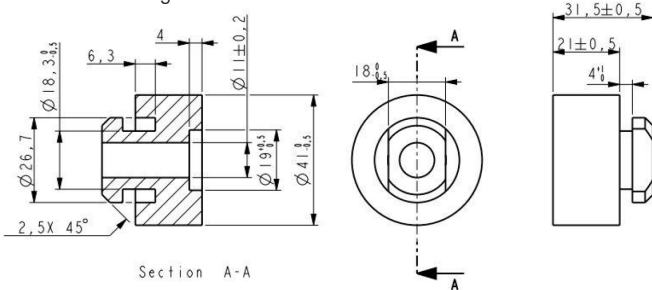

TECHNICAL REQUIREMENTS
1. MATERIAL: EPDM, HARDNESS A
2. UNMARKED TOLERANCE $\pm 0.15 \pm 0.5$.

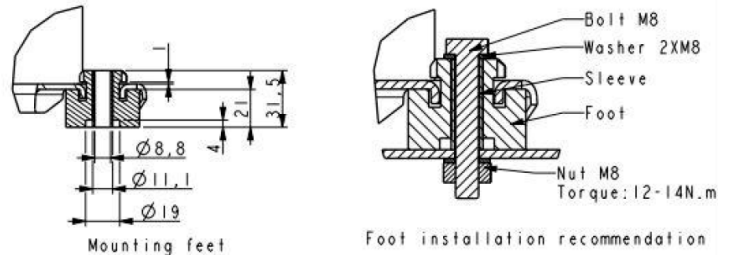

Sleeve Drawing

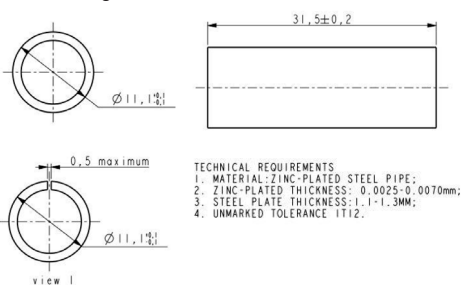

TECHNICAL REQUIREMENTS
1. MATERIAL: ZINC-PLATED STEEL PIPE;
2. ZINC-PLATED THICKNESS: 0.0025-0.0070mm;
3. STEEL PLATE THICKNESS: 1.1-1.3MM;
4. UNMARKED TOLERANCE IT12.

T-Box Layout Standard

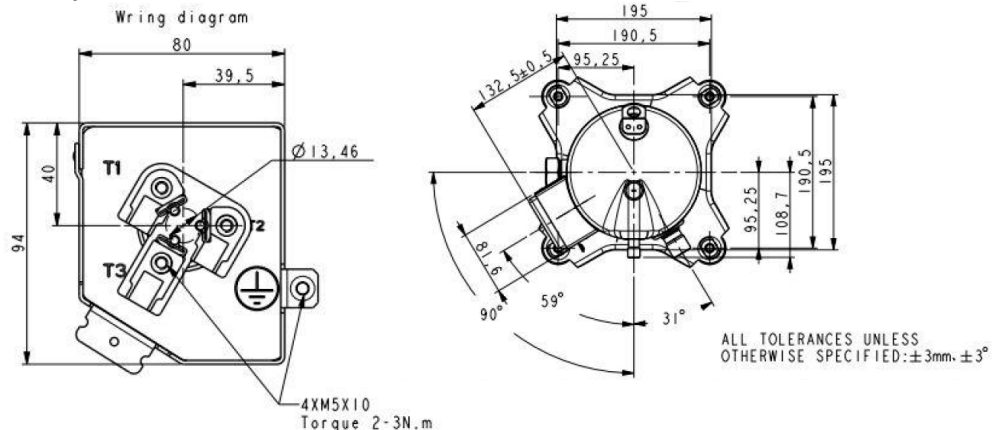

Application

- » See Details in the YM serial MBP refrigerant scroll compressor application manual